

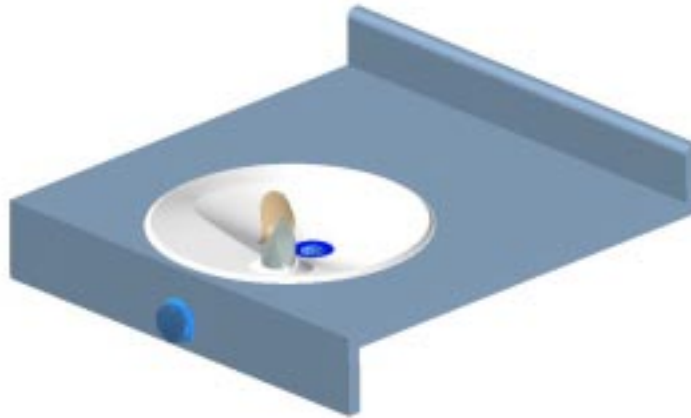



 **ELKAY** With FLEXI-GUARD<sup>®</sup>  
**INSTALLATION, CARE & USE MANUAL**

*Countertop Fountains with FLEXI-GUARD<sup>™</sup>*



INSTALLER

-  **CAUTION:** Review these instructions before beginning installation. Be sure that installation conforms to all plumbing, electrical and other applicable codes.
-  **WARNING:** When installation is complete, ensure these instructions are left in the plastic bag provided inside the installed unit for future reference.
-  **WARNING:** Service to be performed by authorized service personnel only.

NOTE: It is common practice to ground electrical hardware such as telephones, computers and other devices to available water lines. This can, however, cause electrical feedback in the plumbing circuit, which results in an “electrolysis” effect occurring in the fountain. This may result in water which has a metallic taste to it or has a noticeable increase in the metallic content of the water.

When inspecting plumbing circuit, remember the line may be grounded some distance from the installation, and may occur outside the building or area in which the unit is being installed.

This condition can be avoided (in most cases) by using recommended materials during installation. Any drain fittings provided by the installer should be made of **plastic** which will electronically isolate the fountain from the remainder of the building’s plumbing circuits.

DRKR14RC, DRKRV14RC

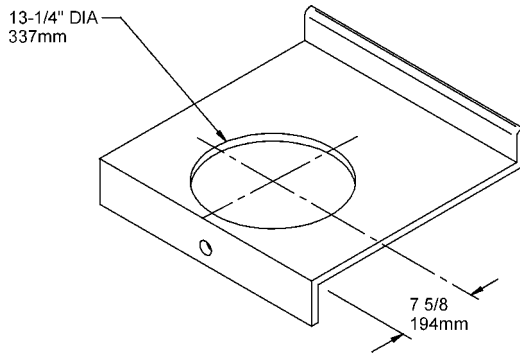

Figure 1



Figure 2

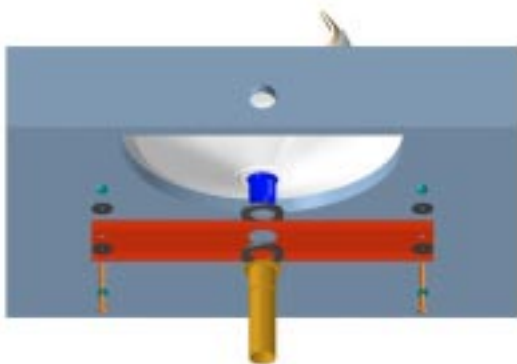
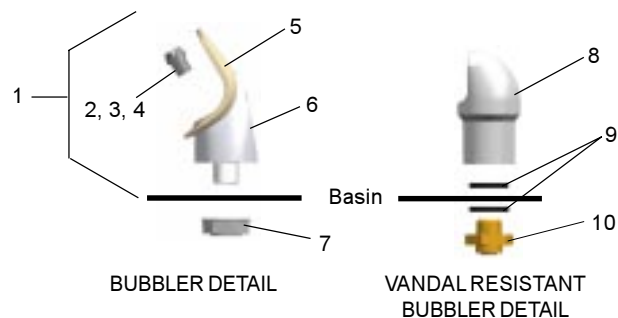

Figure 3

1. Make 13-1/4" (337mm) diameter cutout in desired location on countertop. Maintain the 7-5/8" (194mm) dimension from the front edge for ADA compliance. (See Figure 1)
2. Install bubbler assembly to fountain. Align recess in underside of bubbler with dimple in fountain.
3. Apply caulk (not provided) around cutout and waste opening.
4. Place fountain over opening and drop in strainer. (See Figure 2)
5. From underside, position and secure tiedown bracket using waste fitting. (See Figure 3)
6. Use screws with nuts and washers (provided) to tighten unit to countertop. Wipe off excess caulking. (See Figure 3)
7. Determine required length of waste line and cut to appropriate length. 1-1/4" O.D. waste tube furnished. 1-1/4" slip trap, waste elbow and extension not provided.
8. Make water supply connections from service stop to the 3/8" O.D. unplated copper tube coming out of the strainer. Turn on water supply and check for leaks. Newly installed water supply line should be insulated after leak check is completed.

CAUTION: DO NOT SOLDER tubes into the strainer as damage to the o-rings may result.

9. These products are designed to operate on 20-105 PSIG supply line pressure. If the supply pressure is above 105 PSIG, a pressure regulator must be installed in the supply line. Any damage caused by reason of connecting these products to supply line pressures lower than 20 PSIG or higher than 105 PSIG is not covered by warranty.
10. Check stream height from bubbler. Stream height is factory set at 45-50 PSI. If supply pressure varies greatly from this, remove push button (Item 14 - Figure 7) and adjust the screw on the regulator (Item 16 - Figure 7). To remove push button, remove setscrew from bottom of sleeve (Item 12). Clockwise adjustment will raise stream height and counterclockwise movement will lower stream height. For best adjustment stream should hit basin approximately 6-1/2" from bubbler.



**NOTE:**

When installing replacement bubbler and pedestal, tighten nut (Item 7) only to hold parts snug in position. Do Not Overtighten.

Figure 4 - Bubbler Details

DRKR14RC, DRKRV14RC

Accepts Countertop  
Thickness Up To 1-5/8"

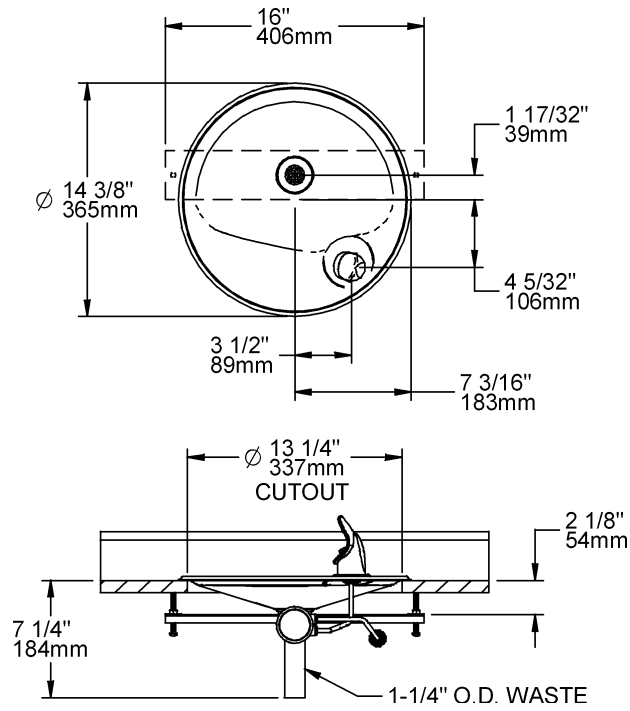

Figure 5

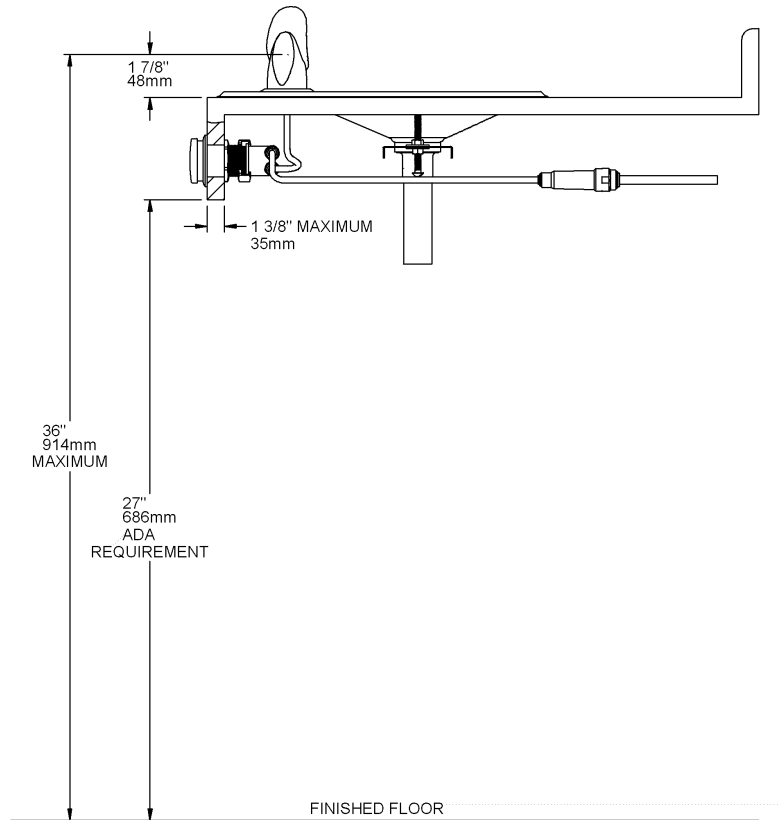

Figure 6

DRKR14RC, DRKRV14RC

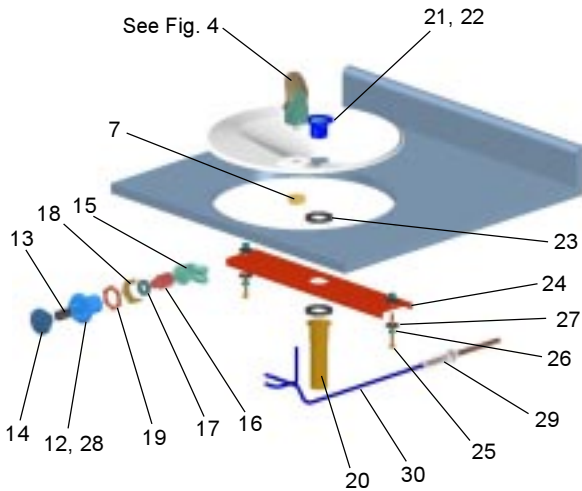

Figure 7

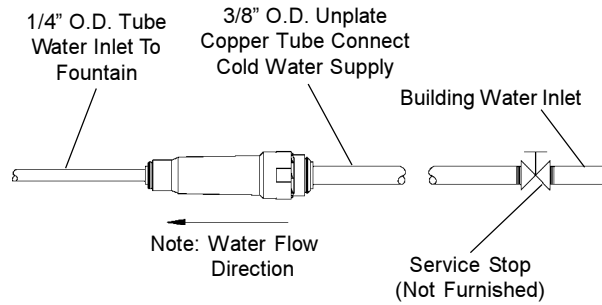

Figure 8 - Water Supply Connections

TROUBLESHOOTING & MAINTENANCE

**Orifice Assembly:** Mineral deposits on orifice can cause water flow to spurt or not regulate. Mineral deposits may be removed from the orifice by poking with a small round file not over 1/8" diameter, or using a small diameter wire.

**CAUTION:** DO NOT file or cut orifice material.

**Stream Regulator:** If orifice is clean, regulate flow as in Step 10, Page 2 of the installation instructions. If replacement is necessary, see parts list for correct regulator part number.

**Actuation of Quick Connect Water Fittings:** Cooler is provided with lead-free connectors which utilize an o-ring water seal. To remove tubing from the fitting, relieve water pressure, push in on the gray collar while pulling on the tubing. (See Figure 9) To insert tubing, push tube straight into fitting until it reaches a positive stop (approximately 3/4").

OPERATION OF QUICK CONNECT FITTINGS

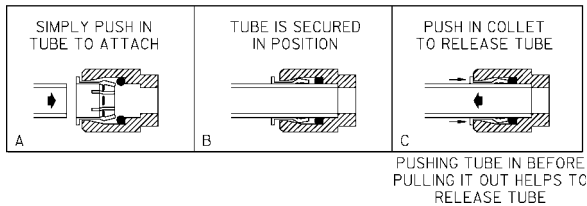

Figure 9 - Quick Connect Fittings

PARTS LIST		
ITEM NO.	PART NO.	DESCRIPTION
1	56073C	Bubbler Assy
2	40319C	Fitting - Orifice
3	50171C	O-Ring
4	50314C	Orifice - Flow Straightener
5	56011C	Housing Assembly
6	55997C	Pedestal
7	75580C	Bubbler Locknut
8	45392C	Body - Bubbler VR
9	100322740560	Gasket - Black .68 x 1.03 VR
10	15009C	Nipple - Bubbler VR
11	55001028	Basin - Swirlflow
12	45738C	Push Button Sleeve
13	56087C	Nylon Rod Extension
14	45662C	Push Button
15	50986C	Holder - Regulator
16	61313C	Regulator
17	15005C	Retaining Nut
18	45736C	Half Nut - Regulator
19	40045C	Hex Nut
20	LK128	Complete Drain Fitting
21	40038C	Grid Strainer
22	40619C	Strainer Body
23	50074C	Rubber Washer
24	55000963	Tie Down Bracket
25	74080022	1/4-20 x 2-1/2 Screw
26	74080005	1/4-20 Hex Nut
27	74080006	1/4 Washer
28	70022C	Setscrew #6-32 x .32"
29	55996C	Strainer
30	56092C	Poly Tubing (Cut To Length)

PRINTED IN U.S.A.

FOR PARTS, CONTACT YOUR LOCAL DISTRIBUTOR OR CALL 1.800.323.0620

ELKAY MANUFACTURING COMPANY • 2222 CAMDEN COURT • OAK BROOK, IL 60523 • 630.574.8484