

Installation/Care/Use Manual

Soft Sides™ Freeze Resistant Fountain

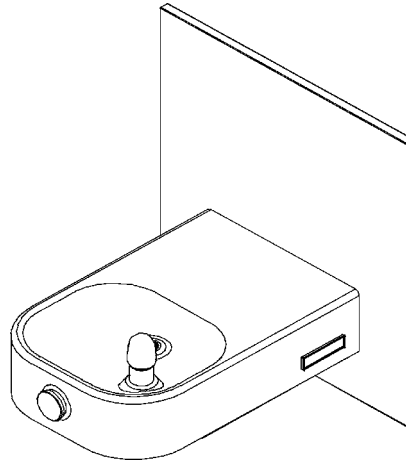

Installer

To assure you install this model easily and correctly, PLEASE READ THESE SIMPLE INSTRUCTIONS BEFORE STARTING THE INSTALLATION. CHECK YOUR INSTALLATION FOR COMPLIANCE WITH PLUMBING, ELECTRICAL AND OTHER APPLICABLE CODES. After installation, leave these instructions inside the fountain for future reference. This Freeze Resistant Fountain is shipped in two separate cartons. The second carton contains the Freeze Resistant Package **LKFRB1** that is installed on an interior heated wall. The interior space must maintain a minimum temperature of 50° F (10° C). Refer to the Freeze Resistant Package for the rough-in dimensions for installation.

IMPORTANT

ALL SERVICE TO BE PERFORMED BY AN AUTHORIZED SERVICE PERSON

IMPORTANT! INSTALLER PLEASE NOTE.

THE GROUNDING OF ELECTRICAL EQUIPMENT SUCH AS TELEPHONE, COMPUTERS, ETC. TO WATER LINES IS A COMMON PROCEDURE. THIS GROUNDING MAY BE IN THE BUILDING OR MAY OCCUR AWAY FROM THE BUILDING. THIS GROUNDING CAN CAUSE ELECTRICAL FEEDBACK INTO A FOUNTAIN, CREATING AN ELECTROLYSIS WHICH CAUSES A METALLIC TASTE OR AN INCREASE IN THE METAL CONTENT OF THE WATER. THIS CONDITION IS AVOIDABLE BY USING THE PROPER MATERIALS AS INDICATED. ANY DRAIN FITTINGS PROVIDED BY THE INSTALLER SHOULD BE MADE OF PLASTIC TO ELECTRICALLY ISOLATE THE FOUNTAIN FROM THE BUILDING PLUMBING SYSTEM.

ECDFPW314FPC

MOUNTING BOLT AND ACCESS HOLE LAYOUT

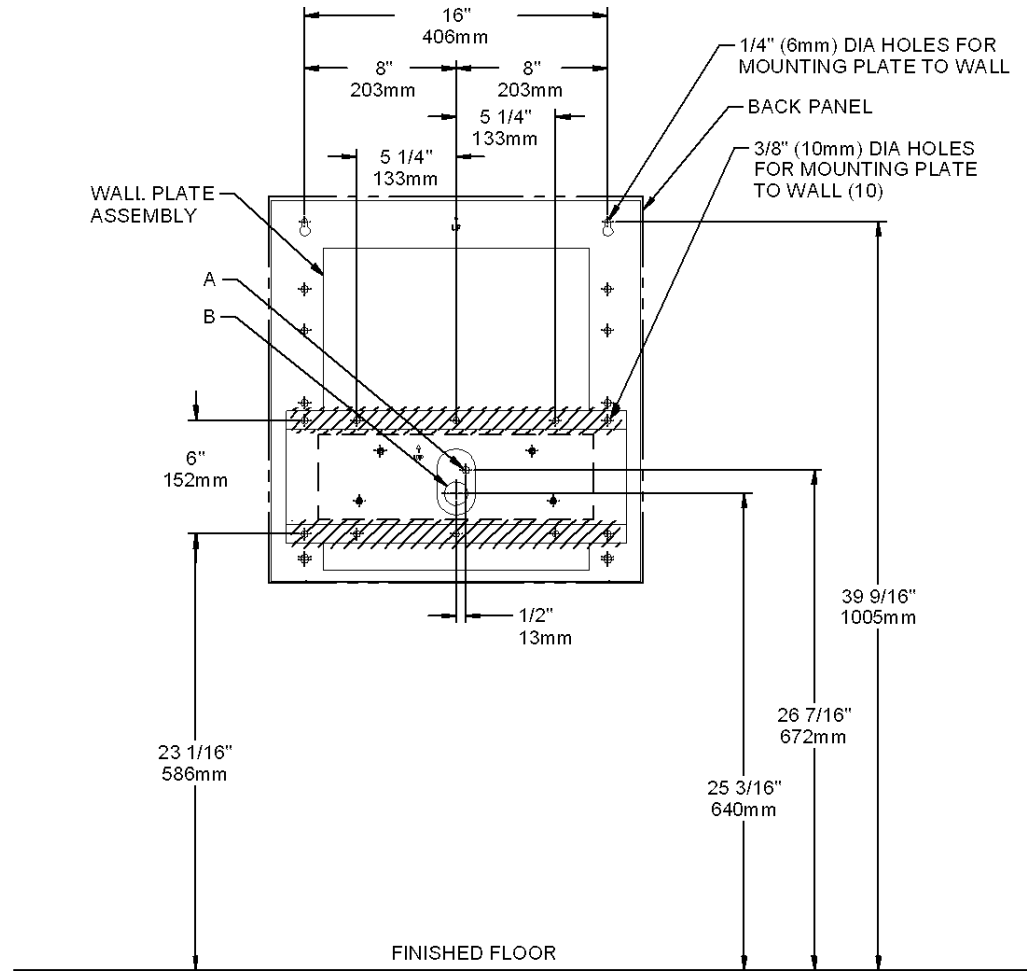
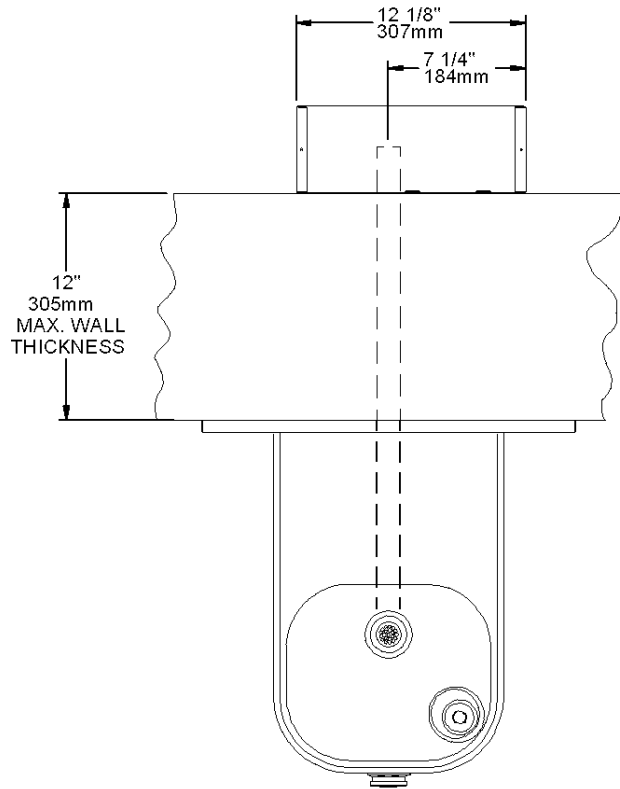

LEGEND

- A = RECOMMENDED WATER SUPPLY LOCATION. 3/8 O.D. UNPLATED COPPER TUBE CONNECT STUBBED 1-1/2" (38mm) FROM WALL. SHUT OFF BY OTHERS.
- B = RECOMMENDED LOCATION FOR WASTE OUTLET 1-1/4" O.D. DRAIN.

NOTE: REINFORCE THE WALL IN THE SHADED AREAS

FIG. 1

ECDFPW314FPC

ROUGH-IN DRAWING

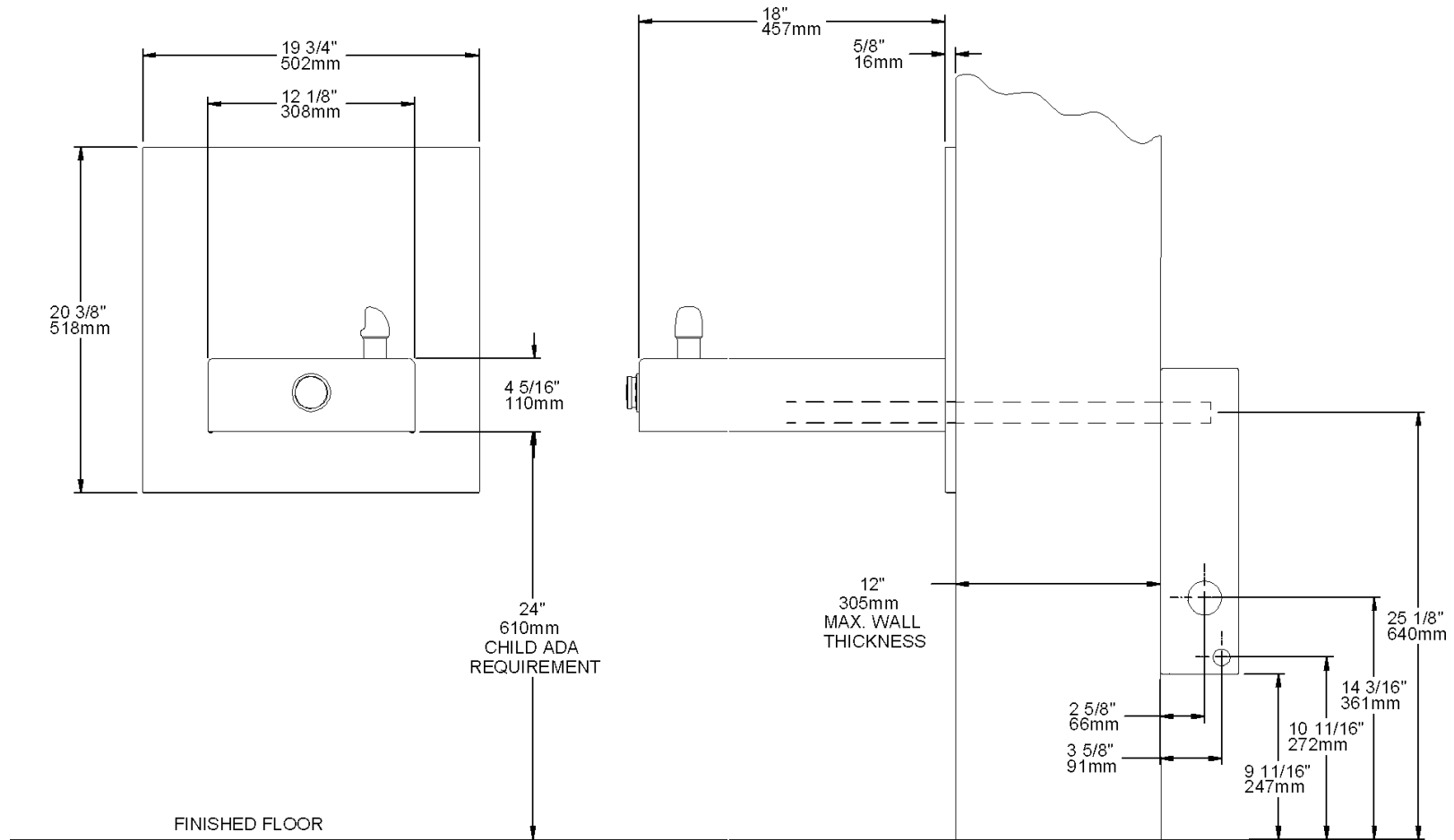

1. Wall should already be framed for the fountains using dimensions shown in Fig. 1. Shown dimensions pertain to installation location.

These dimensions are required for compliance with ANSI Standard A117.1. and ADA (Framing shown for reference only).

2. Remove bottom covers from fountains and save the screws.
3. Install the fountains using bolts and washers (provided). Tighten securely.
4. Attach drain tubes to fountains and cut to required length using the freeze resistant boxes as guides.
5. Install freeze-resistant boxes - see box instructions.
6. Replace bottom covers.

FIG. 2

CABLE SHEATH ADJUSTMENT

To Increase Free Play

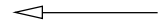
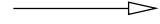

To Reduce Free Play

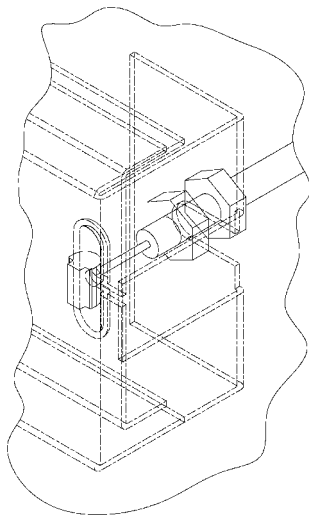

FIG. 3

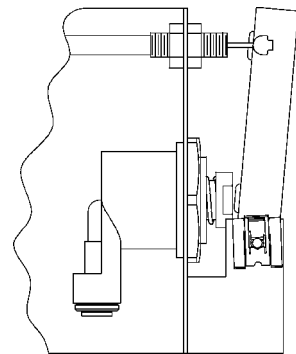
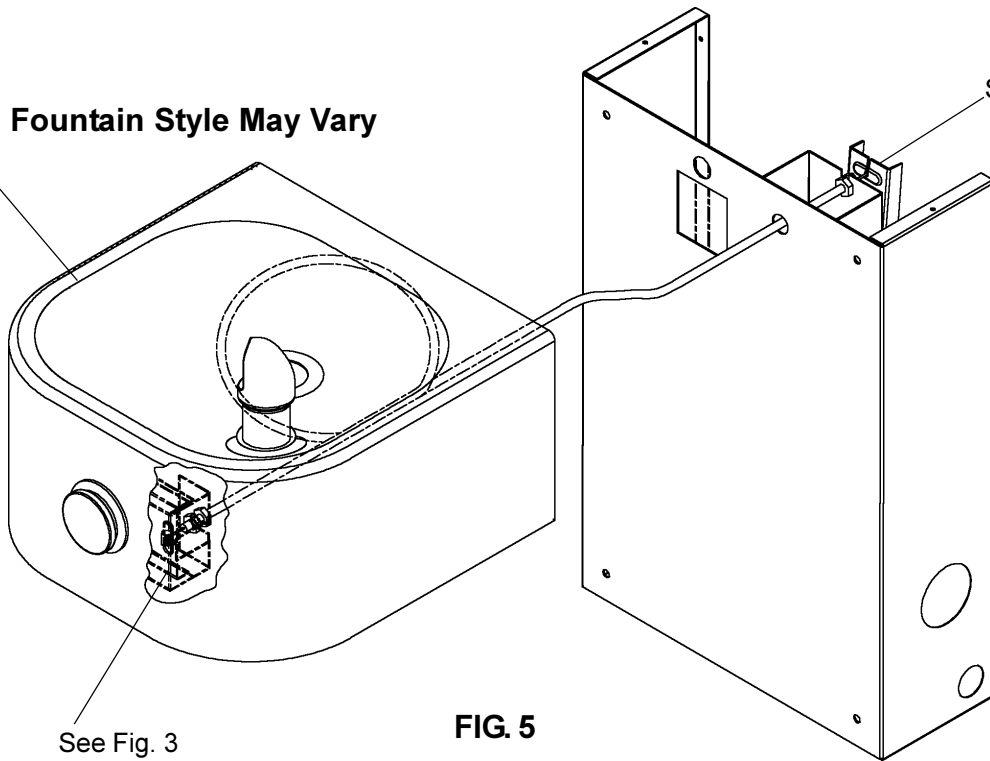

FIG. 4

Note: Fountain Style May Vary



See Fig. 3

FIG. 5

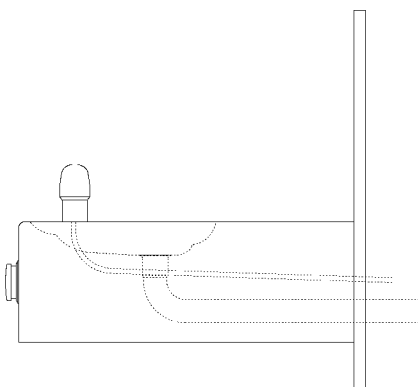

FIG. 6

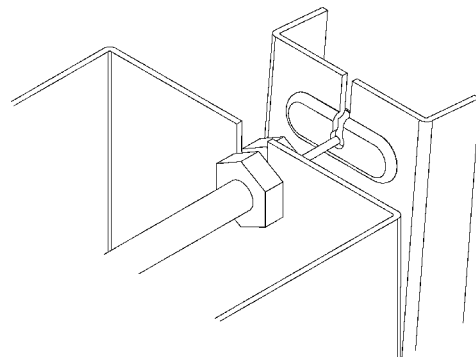

FIG. 7

ECDFPW314FP

The freeze resistant package must be mounted on an interior wall in a heated area. The room temperature of the interior heated area must be 50° F (10° C) or higher. The freeze resistant package may be surface or recessed mounted. If recess mounted the surface of the cover must be flush with the interior wall surface. The package is furnished with screws for mounting the cover to the box. If the box is recess mounted, do not fasten the top and bottom of the cover to the box. Use the holes on the front only.

1. Assemble the operating cable to the fountain bracket. (Fountain should be mounted to exterior wall) Create a loop in the cable and thread the free end of the cable through the wall into the freeze resistant box. The adjustment nuts should be in the middle of threaded area on the operating cable. See Figure 7
2. Connect free end of operating cable to the valve-operating bracket. The end of the cables must be recessed into the indents on the pivot brackets.
3. Remove cable free play by adjusting the jam nuts on the ends of the operating cable. See Figure 4
4. Connect water line from fountain bubbler into freeze resistant box. The connection to the box uses a quick connect water fitting. Position the water line, in the fountain, to drain back into interior mounted box. Any water left standing, in the exterior line, can freeze.

To insert tubing, push tube straight into fitting until it reaches a positive stop. To remove tubing from the fittings, relieve water pressure, push in on dark gray collar while pulling out on the tubing. See Figure 9

5. Connect drain and water supply lines to the freeze resistant fountain. Refer to Figure 1 for component positions. Inline strainer must be used on the inlet water line.

Start-up

1. Turn on building water supply and check all connections for leaks. Repair as required.
2. Stream height is factory set at 35 PSI. If stream height needs to be changed adjust the regulator in the freeze resistant package. Clockwise adjustment raises stream height, counter clockwise adjustment will lower stream.
3. Adjust operating cable as required. Cable system should have a minimal amount of free play to allow for proper valve operation. If the system is too tight the valve will stay in the on position creating constant water flow. Too much free play will result in non-operation of the valve with the push-buttons.
4. Note: Water from the drain back tube in the freeze resistant package, will continue to run while the valve is actuated.
5. After cable system is adjusted properly stuff flexible insulation into any openings between the outside wall and the interior box.
6. Recheck all connections. If all connections are leak free replace cover on the freeze resistant box and fountain.

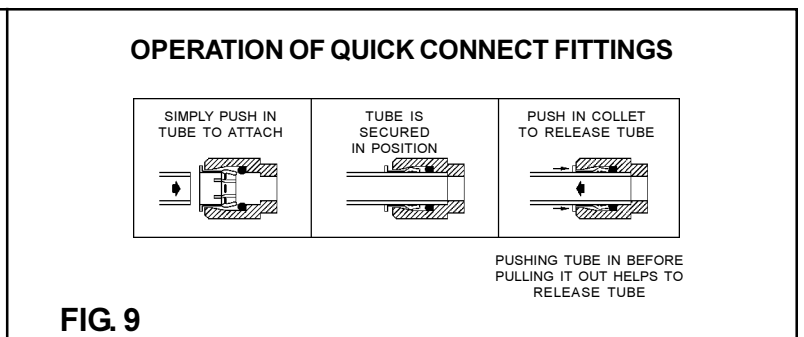
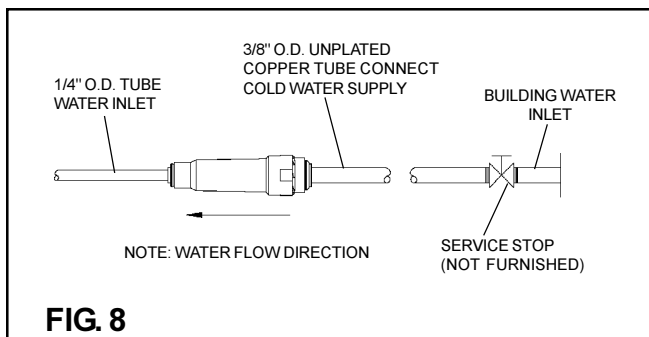

THIS PAGE INTENTIONALLY LEFT BLANK

THIS PAGE INTENTIONALLY LEFT BLANK

ECDFPW314FP

PARTS LIST

ITEM NO.	PART NO.	DESCRIPTION
1	45716C	Drain
2	27057C	Bracket-Regulator Mounting
3	45662C	Push Button
4	45737C	Push Button Sleeve
5	27945C	Bracket-Basin
6	27946C	Bracket-Basin Pivot
7	40206000	Retainer
8	50198C	Snap Bushing
9	51468C	Bumper-Reg. Valve Assy
10	70022C	Set Screw #6-32 X .31"
11	75661C	Screw #8 X .50 Pinned Torx
12	55001129	Fountain Arm - Long
13	55000665	Bottom Cover Plate - Long
14	28290C	Back Panel
15	40045C	Hex Nut
16	70055C	Speed Nut
17	55919C	Push Button (Extension)
18	100322740560	Gasket
19	15009C	Bubbler - Nipple
20	45392C	Bubbler
21	56092C	Poly Tubing (Cut To Length)
22	28286C	Mounting Plate Assy
23	45728C	Drain Ferrule
24	75588C	Nut - Slip Joint
25	75589C	Washer - Seal
26	50074C	Gasket - Tail Pipe
27	45717C	Drain Tube
28	70425C	Pivot Rod
NS	75541C	Washer - Flat .339/.359ID Steel
NS	111577243890	Screw - Mach. 5/16-18 x 3/4
NS	75539C	Wrench-Allen
NS	75523C	Bit-Pinned Torx T-20

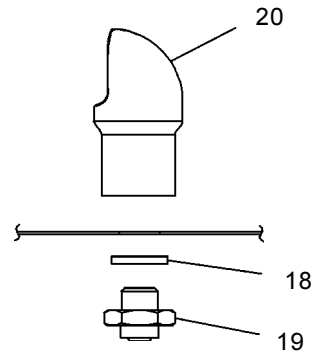

FIG. 10

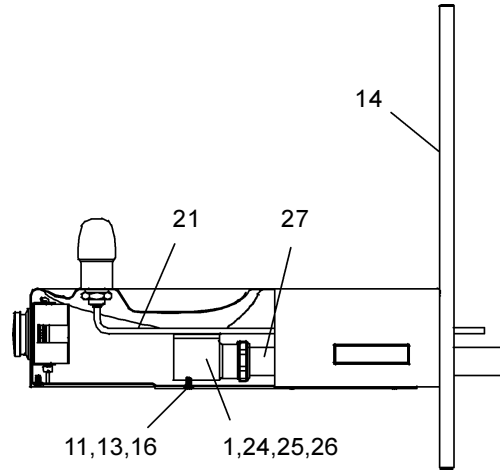

FIG. 12

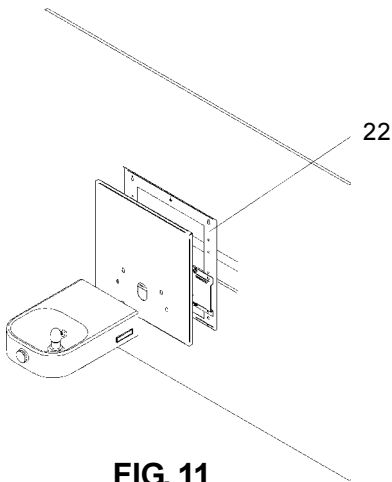

FIG. 11

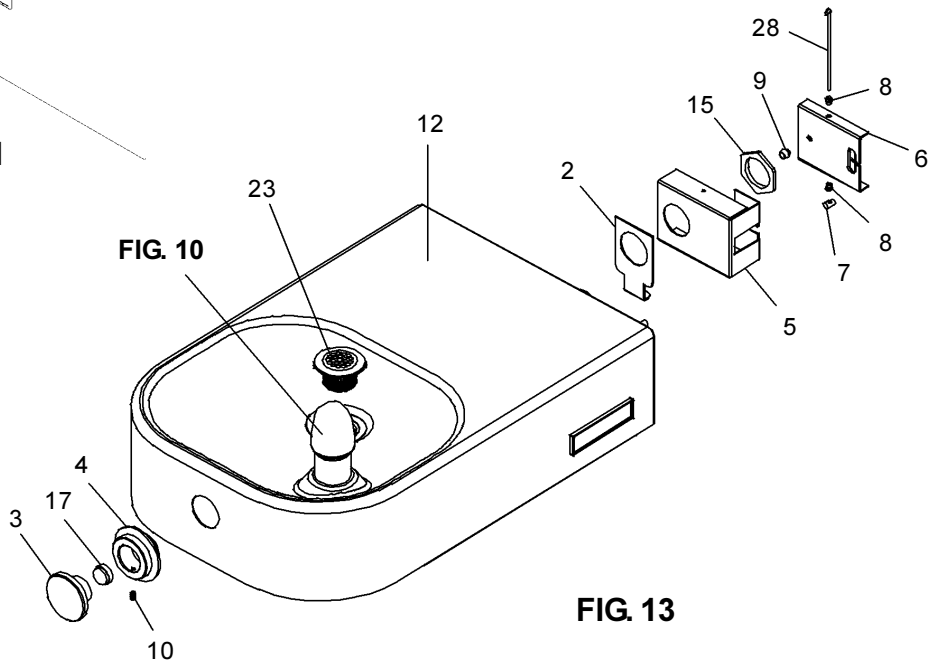

FIG. 13

FOR PARTS, CONTACT YOUR LOCAL DISTRIBUTOR OR CALL 1.800.323.0620
 ELKAY MANUFACTURING COMPANY • 2222 CAMDEN COURT • OAK BROOK, IL 60523 • 630.574.8484