

Installation/Care/Use Manual

SEMI AND FULLY RECESSED WALL MOUNT CUSPIDOR ONLY

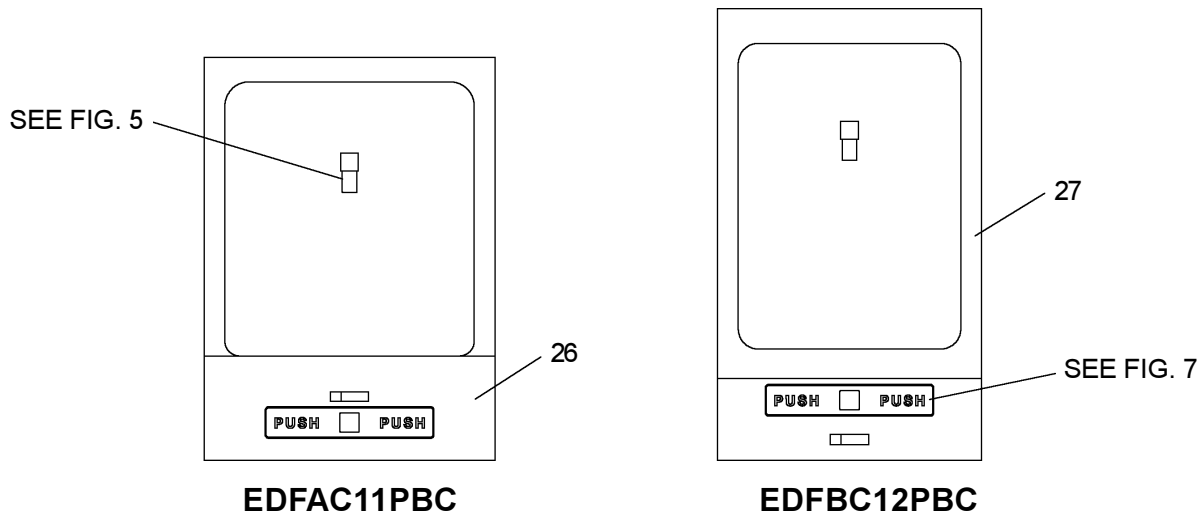

Installer

To assure you install this model easily and correctly, PLEASE READ THESE SIMPLE INSTRUCTIONS BEFORE STARTING THE INSTALLATION. CHECK YOUR INSTALLATION FOR COMPLIANCE WITH PLUMBING, ELECTRICAL AND OTHER APPLICABLE CODES. After installation, leave these instructions inside the fountain for future reference.

IMPORTANT

ALL SERVICE TO BE PERFORMED BY AN AUTHORIZED SERVICE PERSON

IMPORTANT! INSTALLER PLEASE NOTE.

THE GROUNDING OF ELECTRICAL EQUIPMENT SUCH AS TELEPHONE, COMPUTERS, ETC. TO WATER LINES IS A COMMON PROCEDURE. THIS GROUNDING MAY BE IN THE BUILDING OR MAY OCCUR AWAY FROM THE BUILDING. THIS GROUNDING CAN CAUSE ELECTRICAL FEEDBACK INTO A FOUNTAIN, CREATING AN ELECTROLYSIS WHICH CAUSES A METALLIC TASTE OR AN INCREASE IN THE METAL CONTENT OF THE WATER. THIS CONDITION IS AVOIDABLE BY USING THE PROPER MATERIALS AS INDICATED. ANY DRAIN FITTINGS PROVIDED BY THE INSTALLER SHOULD BE MADE OF PLASTIC TO ELECTRICALLY ISOLATE THE FOUNTAIN FROM THE BUILDING PLUMBING SYSTEM.

INSTALLATION INSTRUCTIONS

1. Remove lower panel from cuspidor by removing the two screws at the lower corners. Rotate the bottom of the panel out and pull gently downward to remove.
2. Install spreader assembly into cuspidor body and attach straight end of copper tubing as shown in Figure 5. Route the tubing into the cuspidor compartment and install cuspidor body.
3. Water inlet tube to be 3/8" O.D unplated copper. Waste tailpiece for slip trap is 1-1/4" O.D. Contractor to supply waste trap in accordance with local codes.
4. Connecting lines to be unplated copper and thoroughly flushed to remove all foreign matter before connection to cuspidor assembly. The furnished strainer should be installed in the supply line. See Figure 1 **DO NOT SOLDER TUBES INSERTED INTO THE STRAINER AS DAMAGE TO THE O-RINGS MAY RESULT.**
5. Connect the cuspidor to supply line with shut off valve and install a 3/8" (10mm) water line between the valve and cuspidor.

FIG. 1

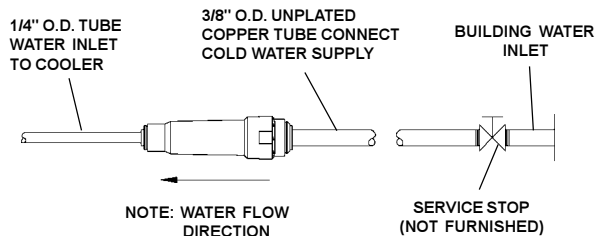
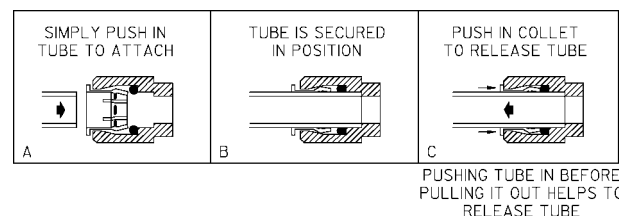

FIG. 2

OPERATION OF QUICK CONNECT FITTINGS



EDFAC11PBC ROUGH-IN

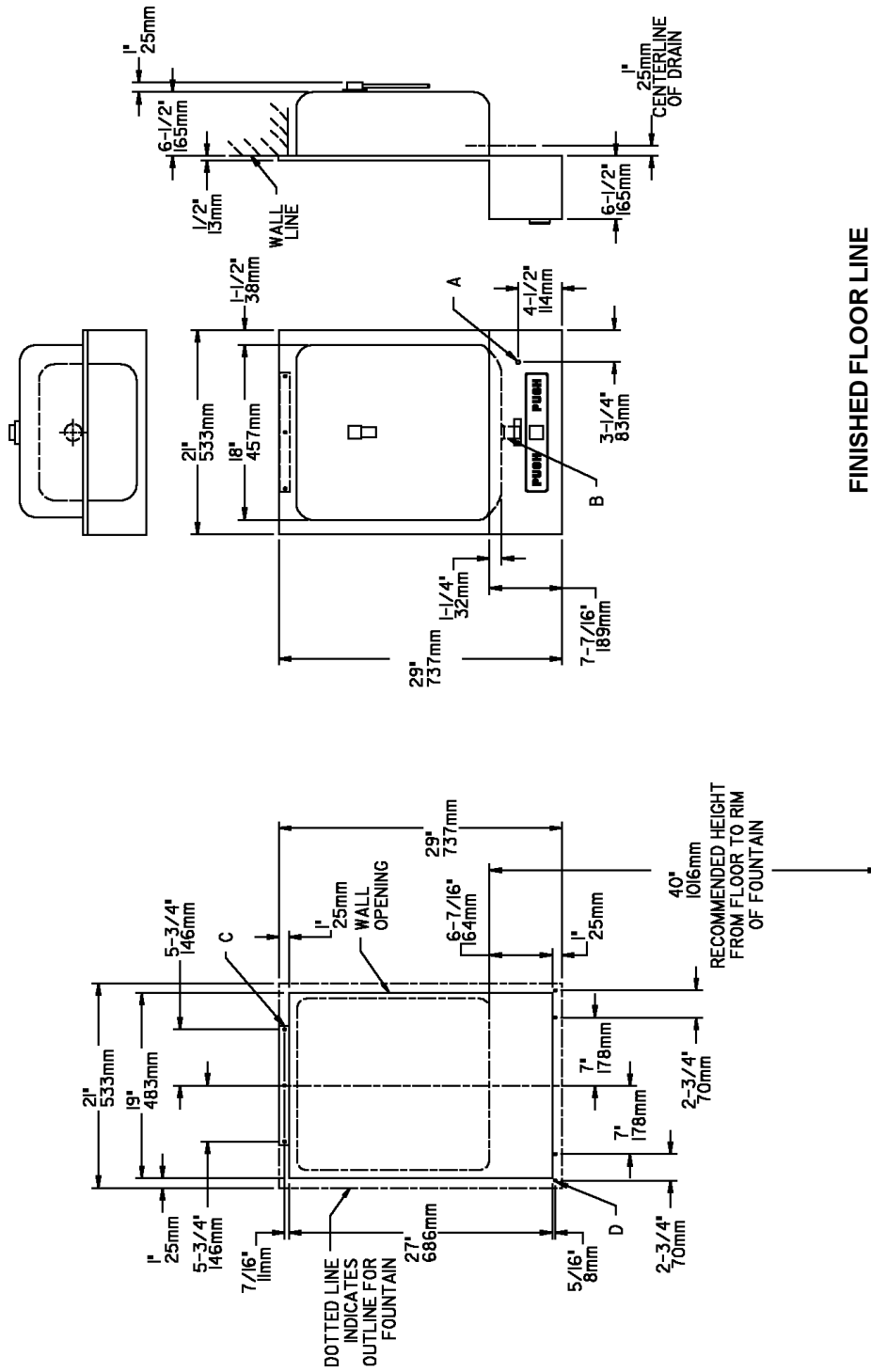

FIG. 3

LEGEND:
 A = WATER INLET LOCATION. 3/8" O.D. UNPLATED COPPER TUBE CONNECT.
 B = CUSPIDOR WASTE OUTLET LOCATION. 1-1/4" O.D. DRAIN (TRAP NOT FURNISHED)
 C = WALL HANGER - 12" (305mm) x 1" (25mm) FURNISHED LOOSE.
 D = MOUNTING HOLES FOR 1/4" DIA. (6mm) SCREWS.

EDFAC11PBC*A EDFBC12PBC*A

PARTS LIST		
ITEM NO.	PART NO.	DESCRIPTION
1	15005C	RETAINING NUT
2	21705C	CLIP - PUSH ROD
3	21708C	PUSH BAR ASSY
4	22911C	LEVER - PUSH
5	22912C	BRACKET - PUSH BAR MTG
6	40575C	STRAINER & FERRULE ASSY
7	40038C	STRAINER - TAILPIPE
8	40045C	HEX NUT
9	40572C	TAILPIPE
10	40573C	FERRULE
11	40206000	RETAINER
12	40624C	HEAD - SPREADER
13	50074C	GASKET - TAILPIPE
14	50198C	BUSHING - NYLON
15	50986C	HOLDER - REGULATOR
16	61314C	REGULATOR
17	70002C	SCREW - #10 X .50 HHSM
18	70018C	NUT - 1/4-20 HEX
19	70278C	ROD - SUPPORT
20	75555C	CLIP
21	70378C	ROD - PUSH
22	55996C	STRAINER
23	70920C	ROD - PIVOT
24	70971C	ELBOW
25	70977C	NUT - LOCK 1/2 CONDUIT
26	55001100	CUSPIDOR (EDFAC11PBC)
27	55001091	CUSPIDOR (EDFBC12PBC)

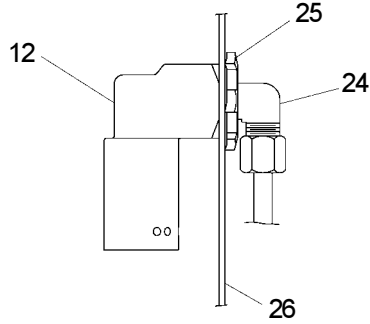

FIG. 5

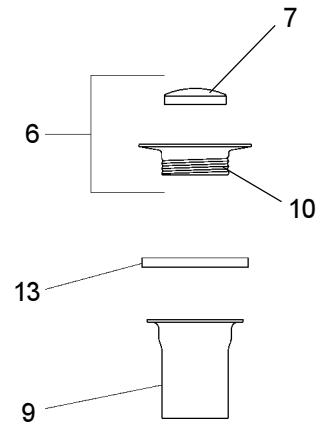
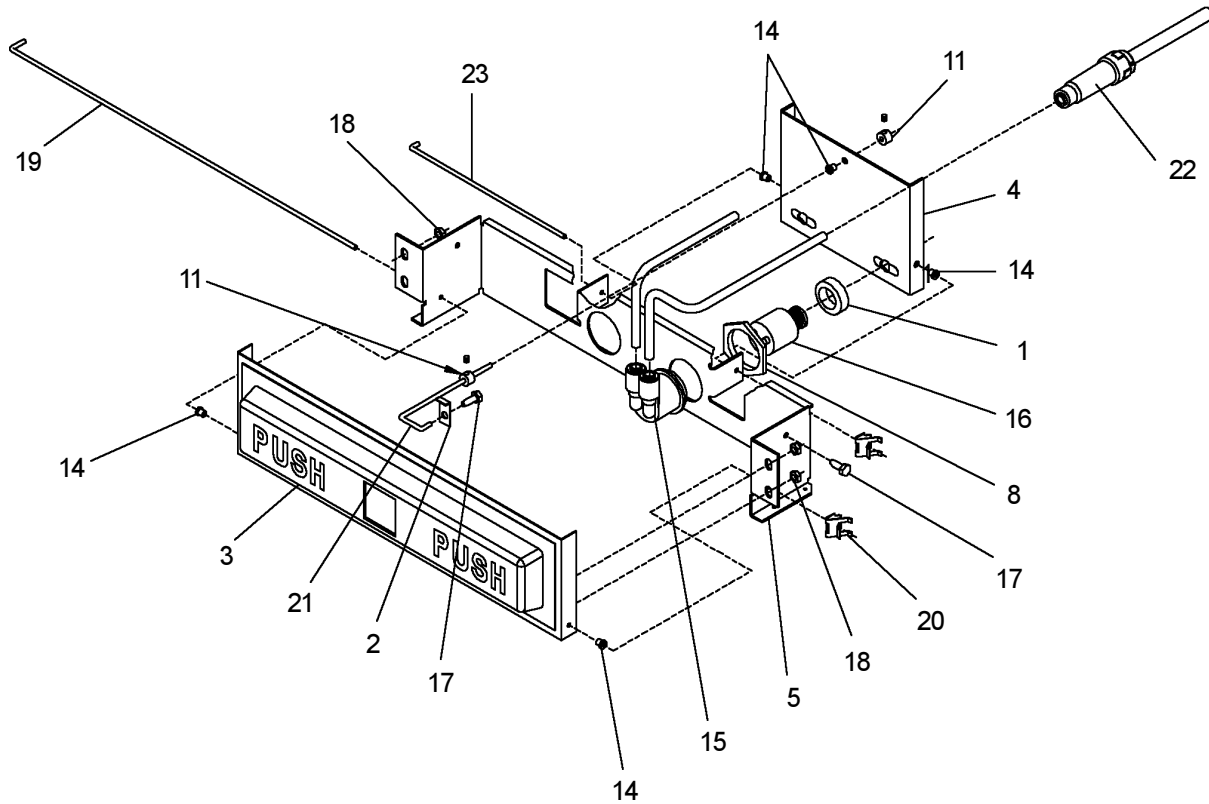

FIG. 6

FIG. 7



FOR PARTS, CONTACT YOUR LOCAL DISTRIBUTOR OR CALL 1.800.323.0620
 ELKAY MANUFACTURING COMPANY • 2222 CAMDEN COURT • OAK BROOK, IL 60523 • 630.574.8484