

Installation/Care/Use Manual

EDFP210FPC EDP214FPC EDP217FPC
Soft Sides™ Freeze Resistant Fountains

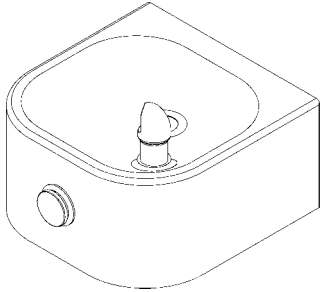

EDFP210FPC

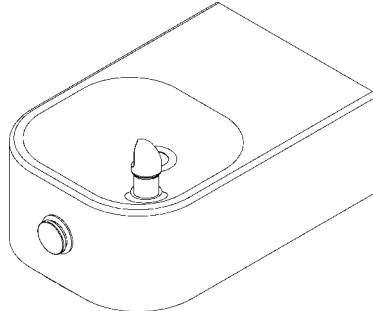

EDFP214FPC

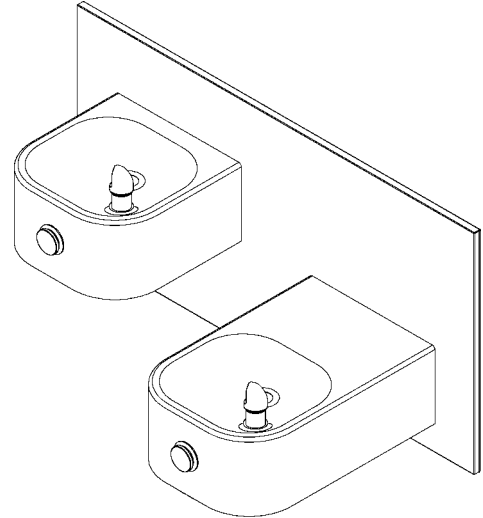

EDFP217FPC

Installer

To assure you install this model easily and correctly, PLEASE READ THESE SIMPLE INSTRUCTIONS BEFORE STARTING THE INSTALLATION. CHECK YOUR INSTALLATION FOR COMPLIANCE WITH PLUMBING, ELECTRICAL AND OTHER APPLICABLE CODES. After installation, leave these instructions inside the fountain for future reference. This Freeze Resistant Fountain is shipped in two separate cartons. The second carton(s) contains the Freeze Resistant Package(s) **LKFRB1** that are installed on an interior heated wall. The interior space must maintain a minimum temperature of 50° F (10° C). Refer to the Freeze Resistant Package for the rough-in dimensions for installation.

IMPORTANT

ALL SERVICE TO BE PERFORMED BY AN AUTHORIZED SERVICE PERSON

IMPORTANT! INSTALLER PLEASE NOTE.

THE GROUNDING OF ELECTRICAL EQUIPMENT SUCH AS TELEPHONE, COMPUTERS, ETC. TO WATER LINES IS A COMMON PROCEDURE. THIS GROUNDING MAY BE IN THE BUILDING OR MAY OCCUR AWAY FROM THE BUILDING. THIS GROUNDING CAN CAUSE ELECTRICAL FEEDBACK INTO A FOUNTAIN, CREATING AN ELECTROLYSIS WHICH CAUSES A METALLIC TASTE OR AN INCREASE IN THE METAL CONTENT OF THE WATER. THIS CONDITION IS AVOIDABLE BY USING THE PROPER MATERIALS AS INDICATED. ANY DRAIN FITTINGS PROVIDED BY THE INSTALLER SHOULD BE MADE OF PLASTIC TO ELECTRICALLY ISOLATE THE FOUNTAIN FROM THE BUILDING PLUMBING SYSTEM.

**EDFP210FP/EDFP214FP
MOUNTING BOLT AND ACCESS HOLE LAYOUT**

FIG. 1

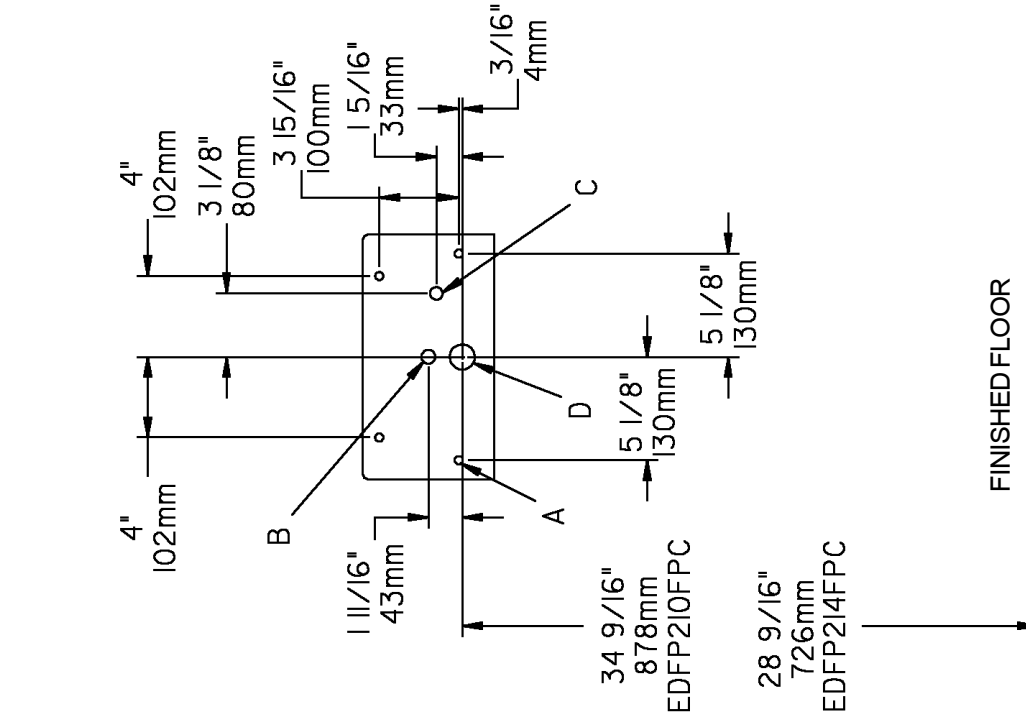

- LEGEND**
- A = MOUNTING BOLT LOCATIONS (4) (3/8" DIA. NOT PROVIDED)
 - B = 7/8" DIA. (22mm) HOLE FOR WATER SUPPLY TUBE
 - C = 7/8" DIA. (22mm) HOLE FOR OPERATING CABLE
 - D = 1-3/4" (44mm) HOLE FOR WASTE LINE

**EDFP210FP/EDFP214FP
ROUGH-IN DRAWINGS**

FIG. 2

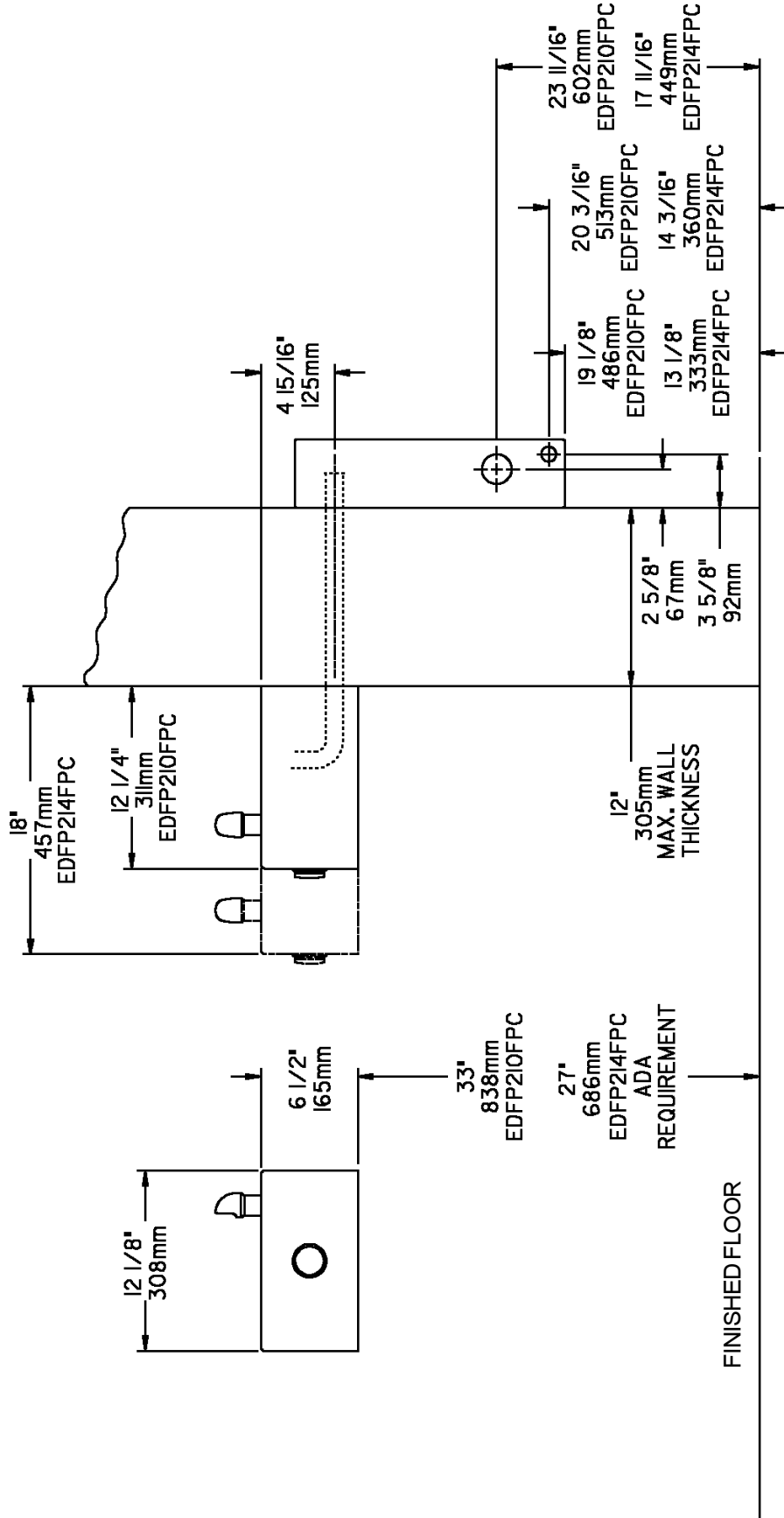

1. Wall should already be framed for the fountain using dimensions shown in Fig. 1. Shown dimensions pertain to installation location. These dimensions are required for compliance with ANSI Standard A117.1. and ADA (Framing shown for reference only).

2. Remove bottom cover from fountain and save the screws.

3. Install the fountain using bolts and washers (not provided). Tighten securely.

4. Attach drain tube to fountain and cut to required length using the freeze resistant box as a guide.

5. Install freeze-resistant box - see box instructions.

6. Replace bottom cover.

**EDFP217FP
MOUNTING BOLT AND ACCESS HOLE LAYOUT**

FIG. 3

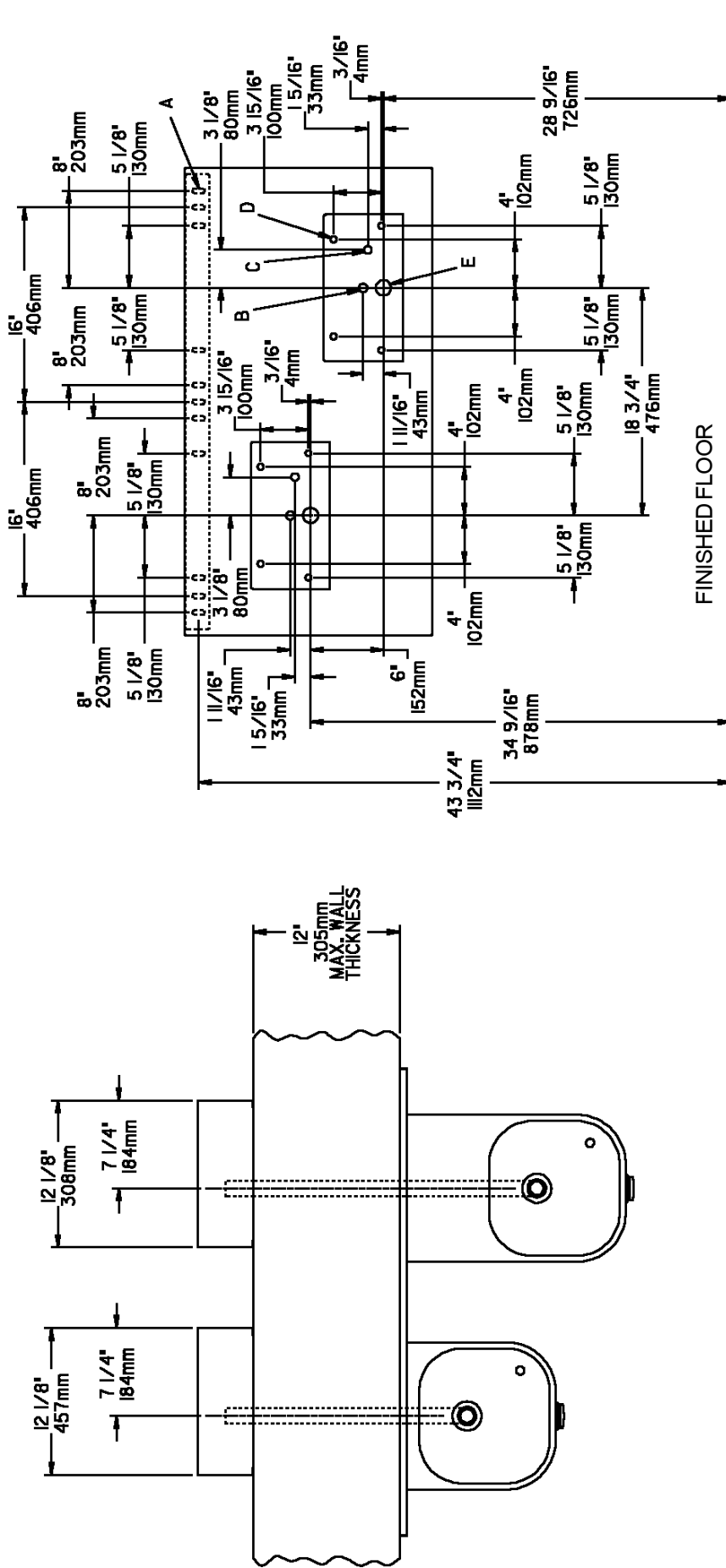

- LEGEND**
- A = 3/8" DIA. (10mm) SLOTS (FOR MOUNTING UPPER HANGER BRACKET)
 - B = 7/8" DIA. (22mm) HOLE FOR WATER SUPPLY TUBE
 - C = 7/8" DIA. (22mm) HOLE FOR OPERATING CABLE
 - D = MOUNTING BOLT LOCATIONS (8) (3/8" DIA. NOT PROVIDED)
 - E = 1-3/4" (44mm) HOLE FOR WASTE LINE

**EDFP217FP
ROUGH-IN DRAWINGS**

FIG. 4

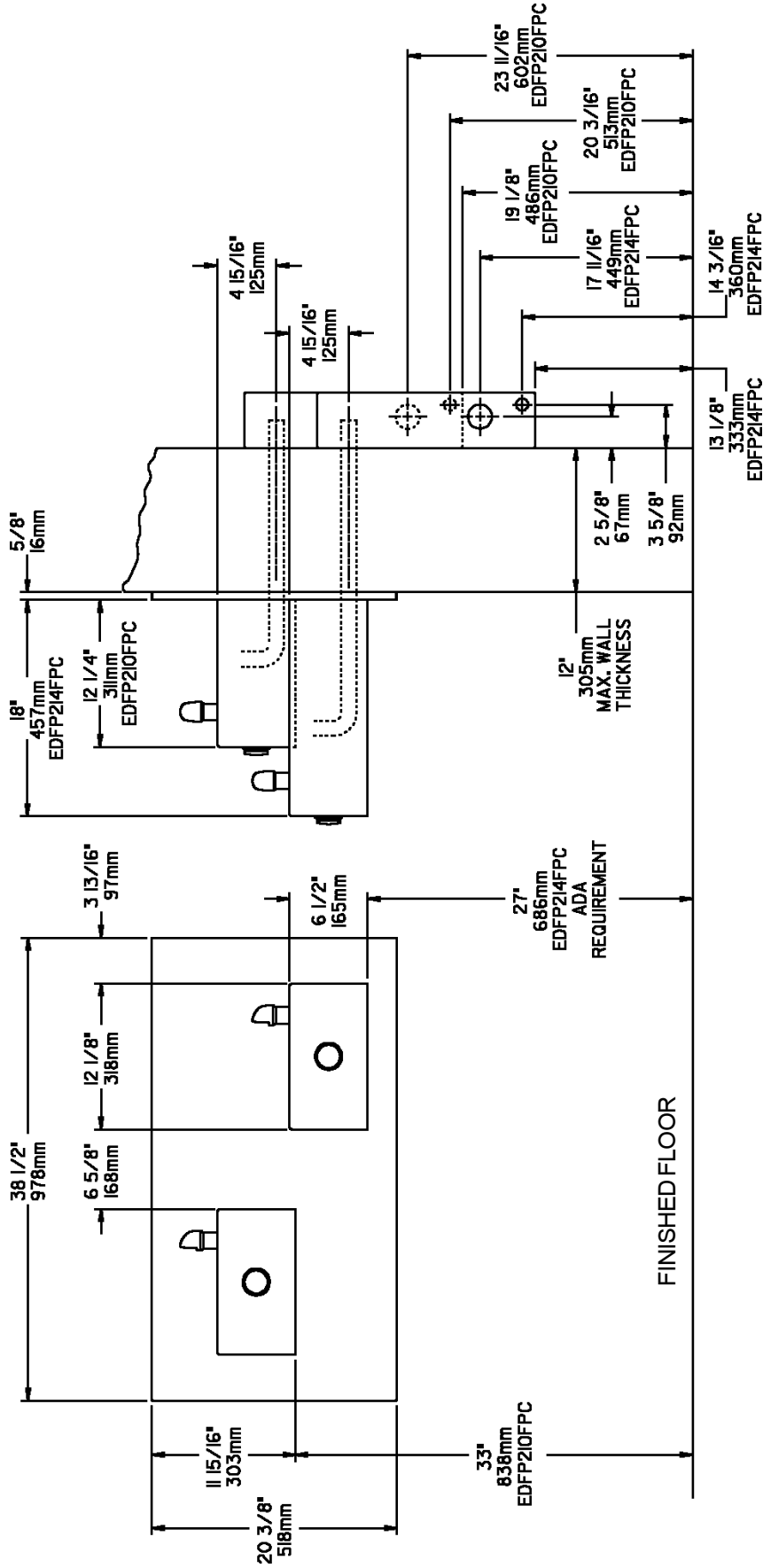

1. Wall should already be framed for the fountains using dimensions shown in Fig. 3. Shown dimensions pertain to installation location. These dimensions are required for compliance with ANSI Standard A117.1, and ADA (Framing shown for reference only).

2. Remove bottom covers from fountains and save the screws.

3. Install the fountains using bolts and washers (not provided). Tighten securely.

4. Attach drain tubes to fountains and cut to required length using the freeze resistant boxes as guides.

5. Install freeze-resistant boxes - see box instructions.

6. Replace bottom covers.

CABLE SHEATH ADJUSTMENT

To Increase Free Play

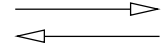

To Reduce Free Play

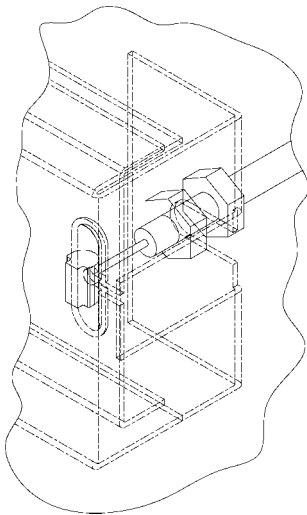

FIG. 5

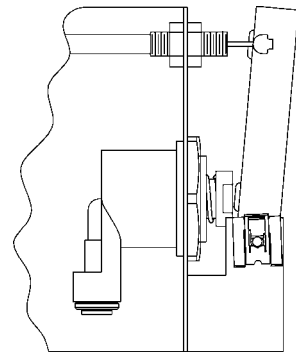

FIG. 6

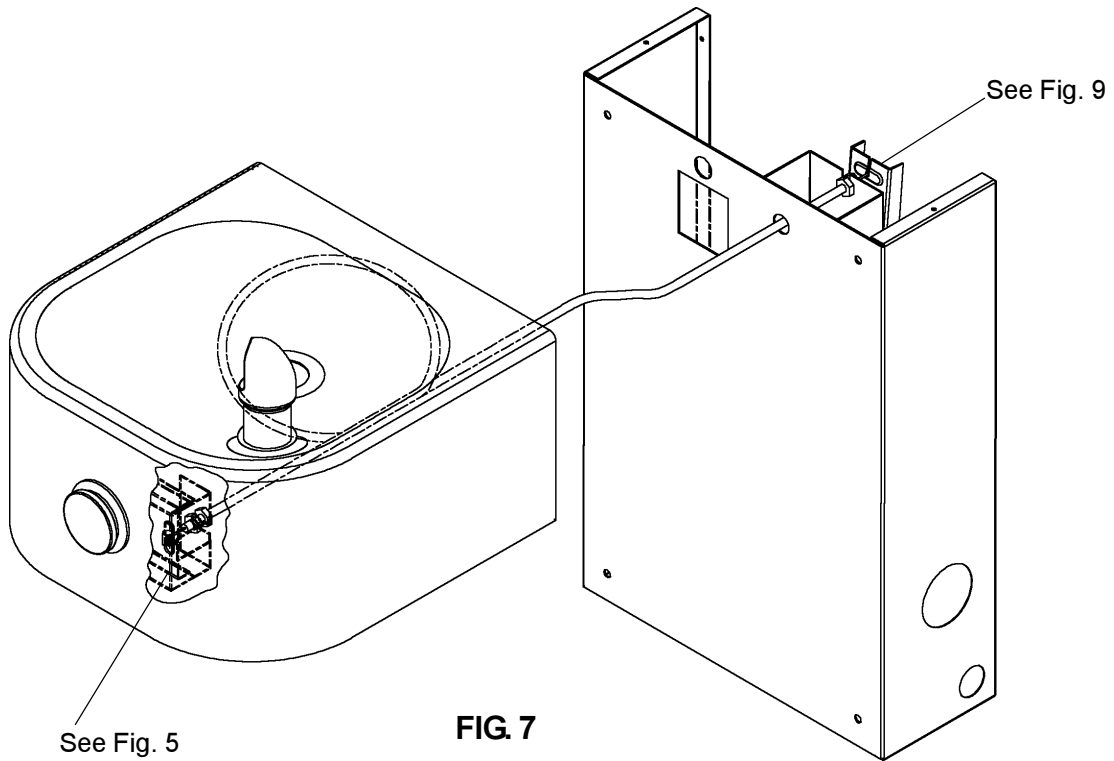

FIG. 7

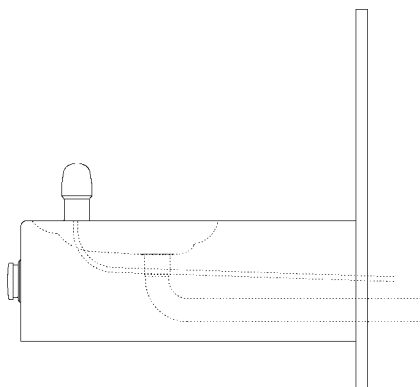

FIG. 8

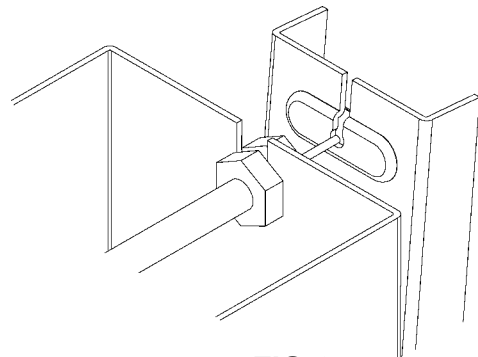

FIG. 9

The freeze resistant package must be mounted on an interior wall in a heated area. The room temperature of the interior heated area must be 50° F (10° C) or higher. The freeze resistant package may be surface or recessed mounted. If recess mounted the surface of the cover must be flush with the interior wall surface. The package is furnished with screws for mounting the cover to the box. If the box is recess mounted, do not fasten the top and bottom of the cover to the box. Use the holes on the front only.

1. Assemble the operating cable to the fountain bracket. (Fountain should be mounted to exterior wall) Create a loop in the cable and thread the free end of the cable through the wall into the freeze resistant box. The adjustment nuts should be in the middle of threaded area on the operating cable. See Figure 9
2. Connect free end of operating cable to the valve-operating bracket. The end of the cables must be recessed into the indents on the pivot brackets.
3. Remove cable free play by adjusting the jam nuts on the ends of the operating cable. See Figure 6
4. Connect water line from fountain bubbler into freeze resistant box. The connection to the box uses a quick connect water fitting. Position the water line, in the fountain, to drain back into interior mounted box. Any water left standing, in the exterior line, can freeze.

To insert tubing, push tube straight into fitting until it reaches a positive stop. To remove tubing from the fittings, relieve water pressure, push in on dark gray collar while pulling out on the tubing. See Figure 11

5. Connect drain and water supply lines to the freeze resistant fountain. Refer to Figure 1 for component positions. Inline strainer must be used on the inlet water line.

Start-up

1. Turn on building water supply and check all connections for leaks. Repair as required.
2. Stream height is factory set at 35 PSI. If stream height needs to be changed adjust the regulator in the freeze resistant package. Clockwise adjustment raises stream height, counter clockwise adjustment will lower stream.
3. Adjust operating cable as required. Cable system should have a minimal amount of free play to allow for proper valve operation. If the system is too tight the valve will stay in the on position creating constant water flow. Too much free play will result in non-operation of the valve with the push-buttons.
4. Note: Water from the drain back tube in the freeze resistant package, will continue to run while the valve is actuated.
5. After cable system is adjusted properly stuff flexible insulation into any openings between the outside wall and the interior box.
6. Recheck all connections. If all connections are leak free replace cover(s) on the freeze resistant box(es) and fountain(s).

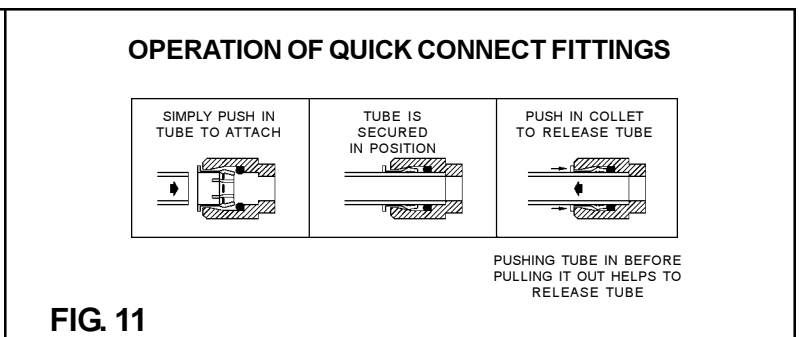
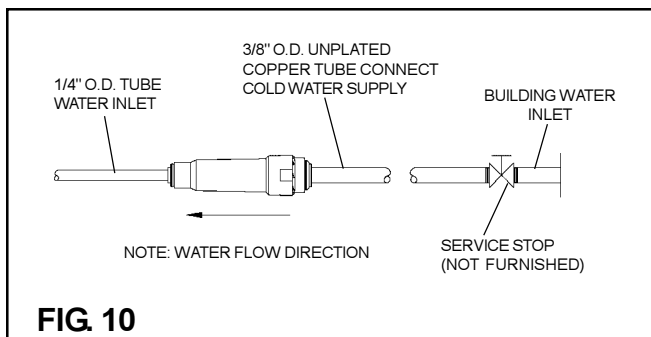

PARTS LIST

ITEM NO.	PARTNO.	DESCRIPTION
1	100322740560	GASKET
2	75499C	SCREW-#8-32 X .50 PINNED TORX
3	15009C	NIPPLE ASSY
4	27057C	BRACKET-REGULATOR MOUNTING
5	27945C	BRACKET-BASIN
6	27946C	BRACKET-BASIN PIVOT
7	40045C	HEX NUT 1-5/16
8	40206000	RETAINER
9	45392C	BUBBLER
10	45662C	PUSH BUTTON
11	45663C	SLEEVE-PUSH BUTTON GUIDE
12	50198C	SNAP BUSHING
13	51468C	BUMPER-REG. VALVE ASSY
14	55919C	PUSH BUTTON (EXTENSION)
15	70425C	PIVOT ROD
16	55000604	FOUNTAINARM - SHORT
	55000612	FOUNTAINARM - LONG
17	55000661	BOTTOM COVER PLATE - SHORT
	55000665	BOTTOM COVER PLATE - LONG
18	27971C	BACK PANEL ASSY - EDP217FPC
19	70022C	SET SCREW-#6-32 X .31
20	70055C	SPEED NUT 8-32
21	72000833	WASTE ARM ASSY
NS	56092C	POLY TUBING (CUT TO LENGTH)
NS	75519C	BIT - PINNED TORX T-15
NS	75539C	WRENCH - ALLEN 1/16

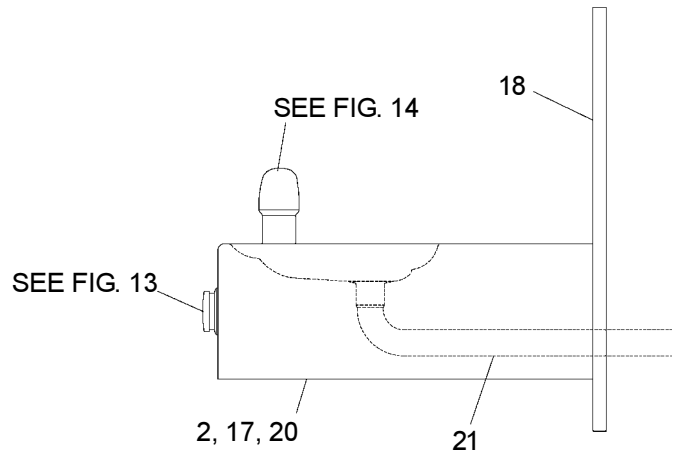

FIG. 12

FIG. 13

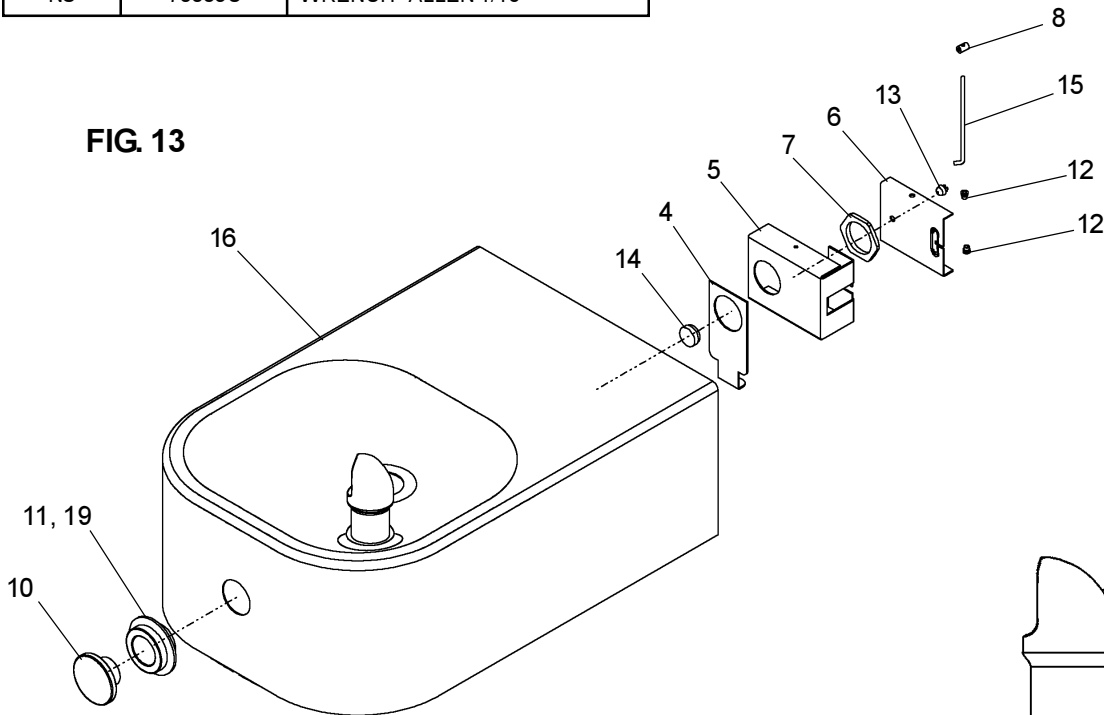
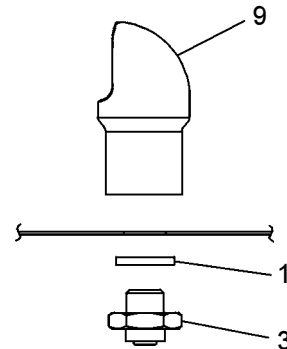

FIG. 14



FOR PARTS, CONTACT YOUR LOCAL DISTRIBUTOR OR CALL 1.800.323.0620
 ELKAY MANUFACTURING COMPANY • 2222 CAMDEN COURT • OAK BROOK, IL 60523 • 630.574.8484