

# Installation/Care/Use Manual

## Non-Refrigerated Fountains with FLEXI-GUARD®

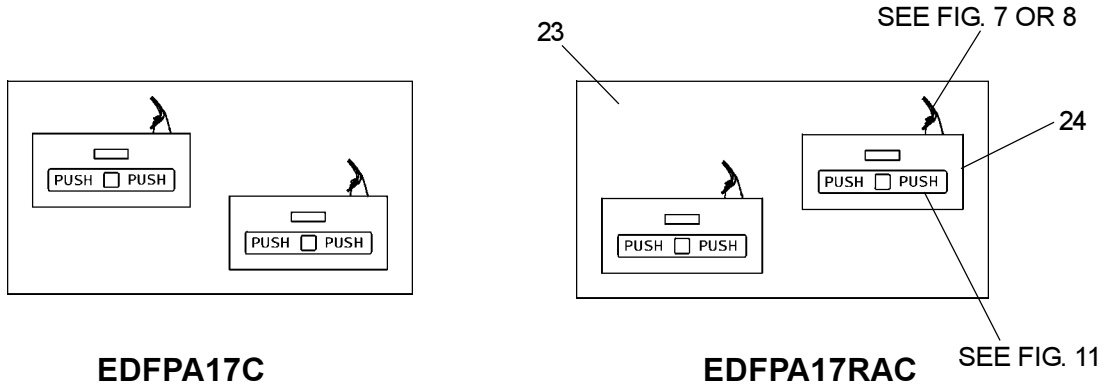

### Installer

To assure you install this model easily and correctly, PLEASE READ THESE SIMPLE INSTRUCTIONS BEFORE STARTING THE INSTALLATION. CHECK YOUR INSTALLATION FOR COMPLIANCE WITH PLUMBING, ELECTRICAL AND OTHER APPLICABLE CODES. After installation, leave these instructions inside the fountain for future reference.

### IMPORTANT

ALL SERVICE TO BE PERFORMED BY AN AUTHORIZED SERVICE PERSON

### IMPORTANT! INSTALLER PLEASE NOTE.

THE GROUNDING OF ELECTRICAL EQUIPMENT SUCH AS TELEPHONE, COMPUTERS, ETC. TO WATER LINES IS A COMMON PROCEDURE. THIS GROUNDING MAY BE IN THE BUILDING OR MAY OCCUR AWAY FROM THE BUILDING. THIS GROUNDING CAN CAUSE ELECTRICAL FEEDBACK INTO A FOUNTAIN, CREATING AN ELECTROLYSIS WHICH CAUSES A METALLIC TASTE OR AN INCREASE IN THE METAL CONTENT OF THE WATER. THIS CONDITION IS AVOIDABLE BY USING THE PROPER MATERIALS AS INDICATED. ANY DRAIN FITTINGS PROVIDED BY THE INSTALLER SHOULD BE MADE OF PLASTIC TO ELECTRICALLY ISOLATE THE FOUNTAIN FROM THE BUILDING PLUMBING SYSTEM.

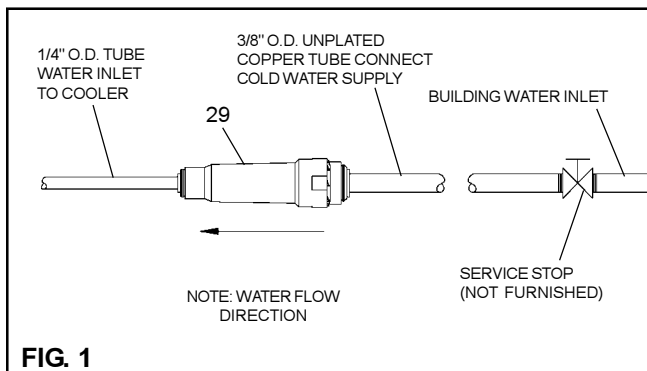

**FIG. 1**

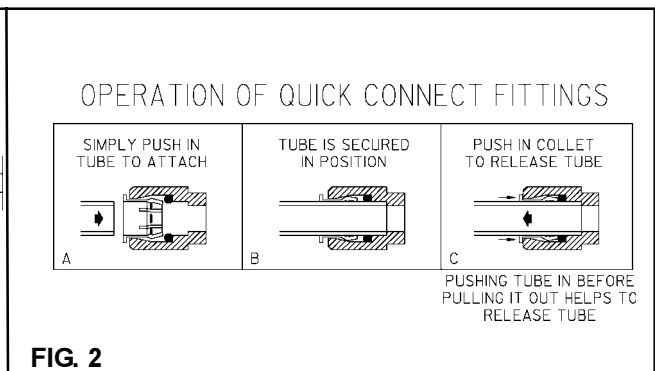

**FIG. 2**

EDFPA17C

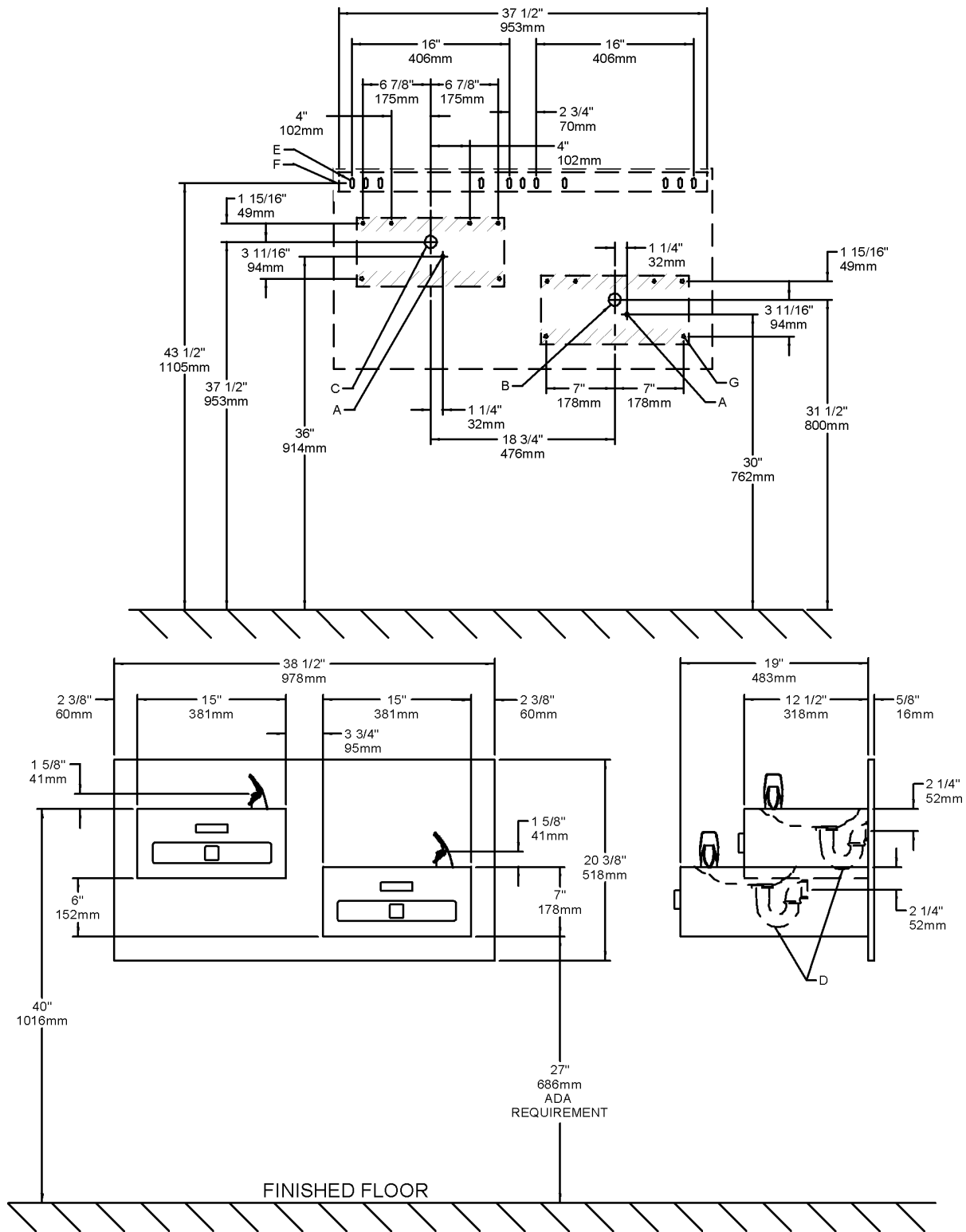

FIG. 3

LEGEND

- A** = RECOMMENDED WATER SUPPLY LOCATION 3/8 O.D. UNPLATED COPPER TUBE CONNECT STUBBED 1" (25mm) FROM WALL SHUT OFF BY OTHERS
- B** = RECOMMENDED LOCATION FOR WASTE OUTLET 1-1/4" O.D. DRAIN STUBBED 1-1/2" (38mm) FROM THE WALL
- C** = RECOMMENDED LOCATION FOR WASTE OUTLET 1-1/4" O.D. DRAIN STUBBED 6-3/4" (171mm) FROM THE WALL
- D** = 1-1/4" TRAP FURNISHED

- E** = 5/16" (8mm) DIA HOLES FOR MOUNTING HANGER TO WALL
- F** = WALL HANGER FURNISHED LOOSE
- G** = 1/4" (6mm) DIA. HOLES FOR SECURING FOUNTAIN TO WALL

NOTE: REINFORCE WALL IN SHADED AREAS

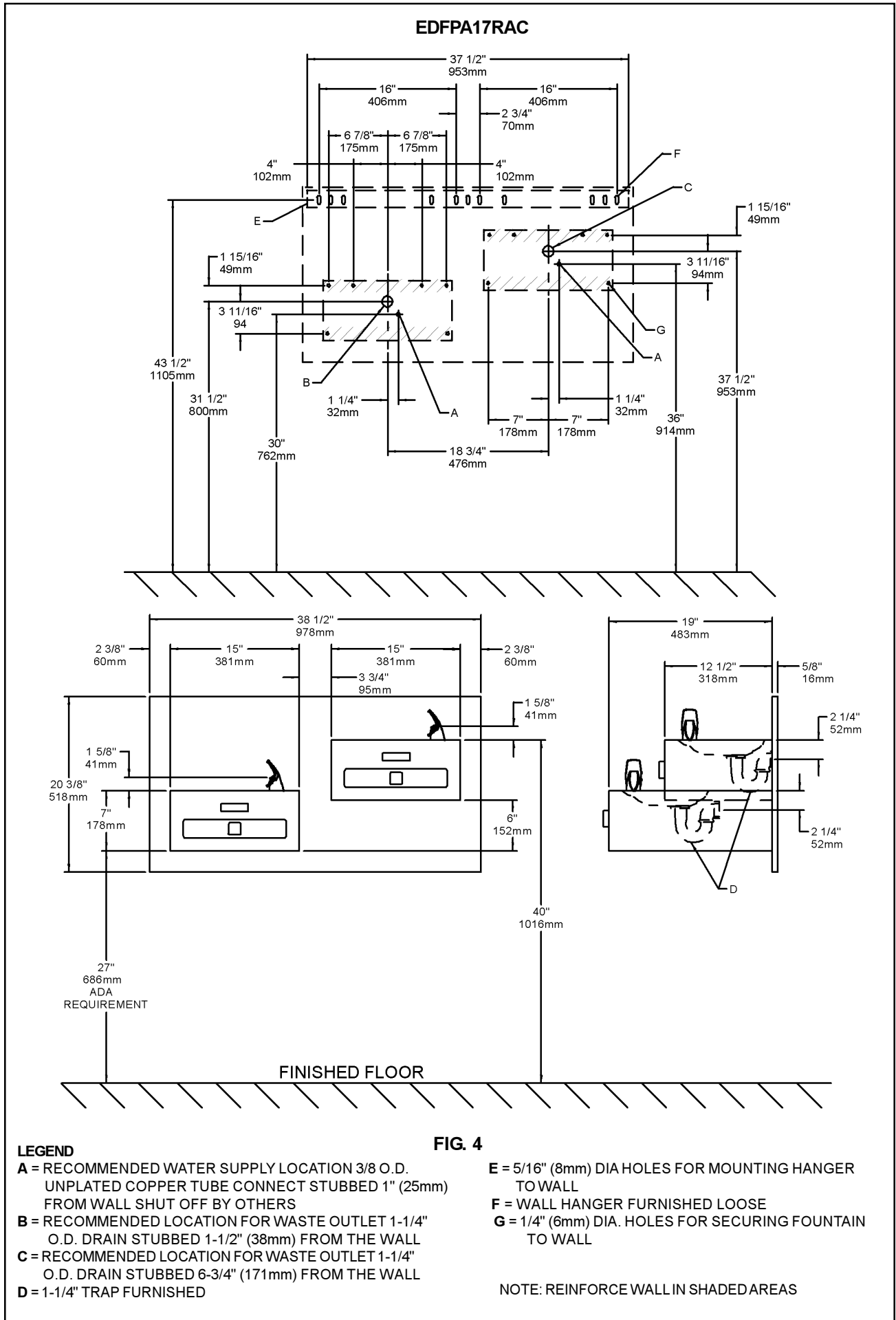

**FIG. 4**

EDFPA17C W/MOUNTING PLATE

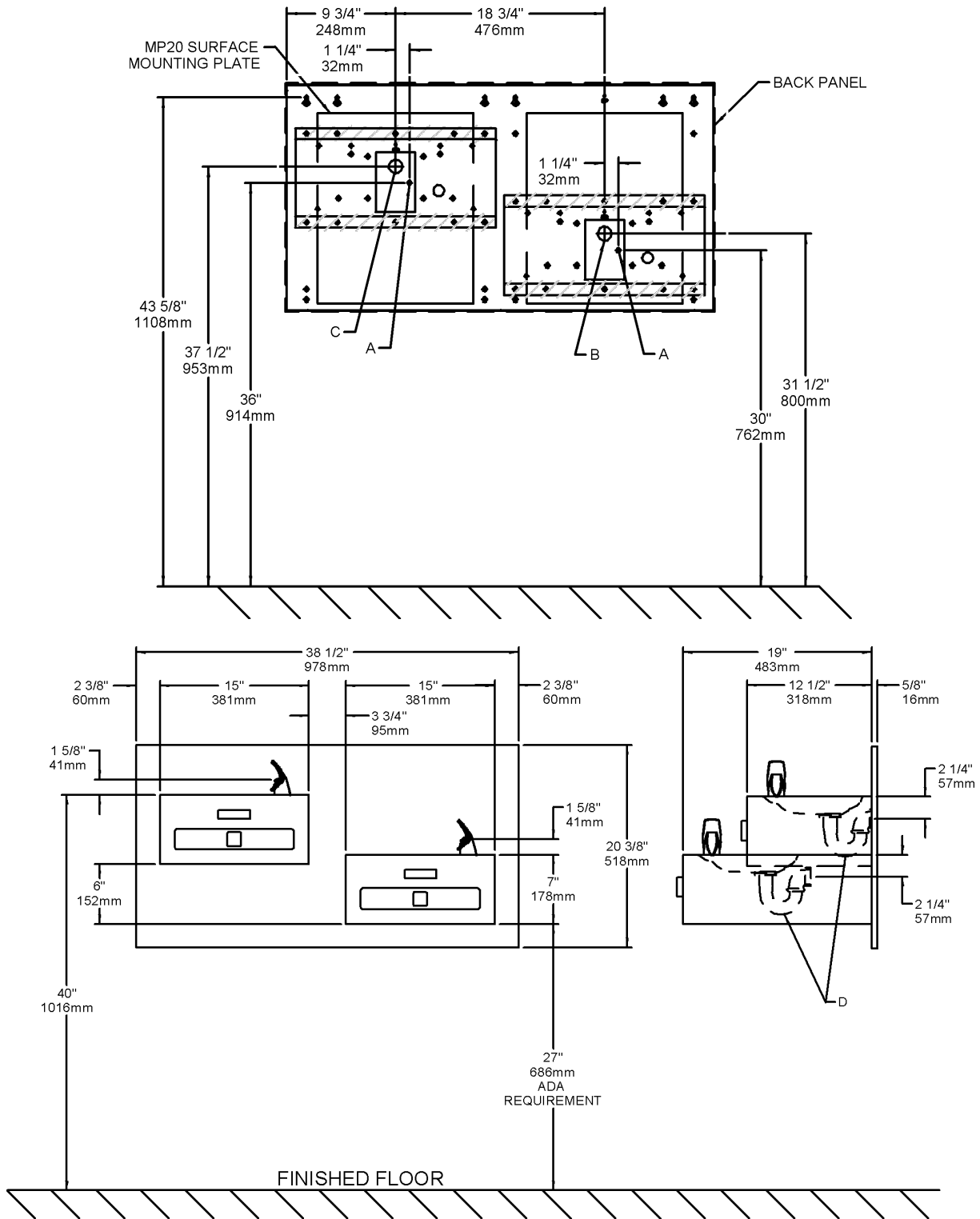

FIG. 5

LEGEND

- A** = RECOMMENDED WATER SUPPLY LOCATION 3/8 O.D. UNPLATED COPPER TUBE CONNECT STUBBED 1" (25mm) FROM WALL SHUT OFF BY OTHERS
- B** = RECOMMENDED LOCATION FOR WASTE OUTLET 1-1/4" O.D. DRAIN STUBBED 1-1/2" (38mm) FROM THE WALL
- C** = RECOMMENDED LOCATION FOR WASTE OUTLET 1-1/4" O.D. DRAIN STUBBED 6-3/4" (171mm) FROM THE WALL
- D** = 1-1/4" TRAP FURNISHED

NOTE: REINFORCE WALL IN SHADED AREAS

EDFPA17RAC W/MOUNTING PLATE

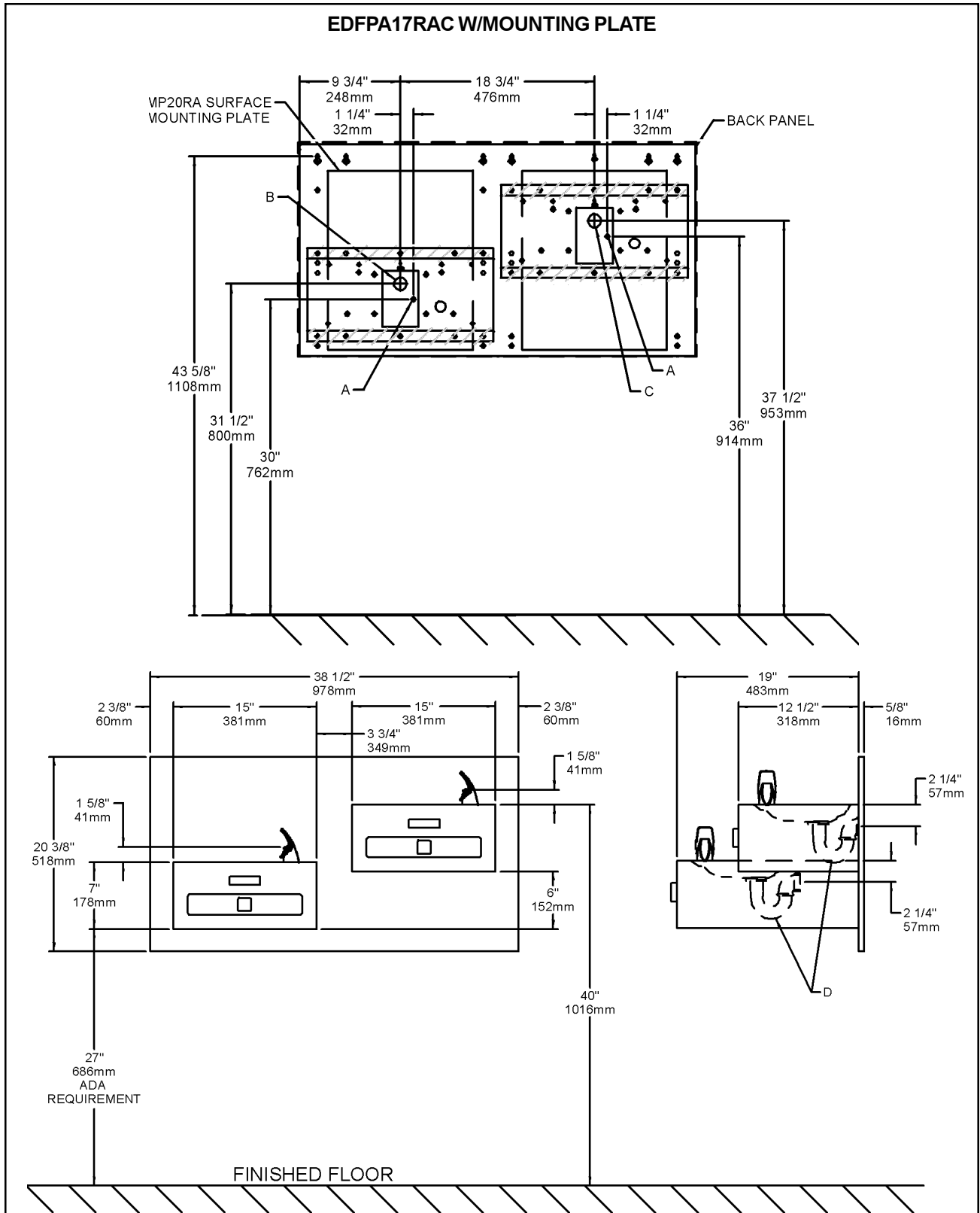

FIG. 6

LEGEND

- A** = RECOMMENDED WATER SUPPLY LOCATION 3/8 O.D. UNPLATED COPPER TUBE CONNECT STUBBED 1" (25mm) FROM WALL SHUT OFF BY OTHERS
- B** = RECOMMENDED LOCATION FOR WASTE OUTLET 1-1/4" O.D. DRAIN STUBBED 1-1/2" (38mm) FROM THE WALL
- C** = RECOMMENDED LOCATION FOR WASTE OUTLET 1-1/4" O.D. DRAIN STUBBED 6-3/4" (171mm) FROM THE WALL
- D** = 1-1/4" TRAP FURNISHED

NOTE: REINFORCE WALL IN SHADED AREAS

## INSTALLATION INSTRUCTIONS

1. **Wall** should already be framed for the fountain using the positioning dimensions shown in Figures 3, 4, 5, or 6. Shown dimensions pertain to installation location (framing must support up to 300 lbs. weight). These dimensions are required for compliance with ANSI Standard A117.1/ADA requirements.
2. **Install** rough-in plumbing as shown in Figures 3, 4, 5, or 6. Waste line should extend a minimum of 2" (51mm) through the back panel. Connecting lines to be unplated copper and thoroughly flushed to remove all foreign matter before connection to fountain. Run the supply water inlet line through the back panel. Install a service stop (not provided). Turn on supply water and flush thoroughly.
3. **Install back panel.**  
**EDFPA17C:** Place the upper edge of the panel above hanger bracket.  
**EDFPA17C W/MOUNTING PLATE:** Place the upper edge of the panel above mounting plate on the wall. Slide the panel down until it engages the mounting plate. Be sure back panel is firmly engaged before releasing it.
4. **Secure the fountain** to the wall.  
**MODEL EDFPA17C:** Install the fountain to the back panel using (2) bolts and washers (not provided) per each fountain. Next secure the fountain bodies and back panel to the wall using (4) bolts and washers (not provided) per each fountain. Tighten securely.  
**MODEL EDFPA17C W/MOUNTING PLATE:** Install the fountain to the back panel using (2) bolts and washers (provided) per each fountain. Next secure the fountain bodies to the back panel using (4) bolts and washers (provided) per each fountain. Tighten securely.
5. **Remove** elbow from end of p-trap and attach it to drain tube. Reattach elbow to p-trap and cut waste tube to required length using plumbing hardware and trap as a guide.
6. **Make** water supply connections from service stop to the 3/8" O.D. unplated copper tube coming out of the strainer. Turn on water supply and check for leaks. Newly installed water supply line should be insulated after leak check is completed. **DO NOT SOLDER TUBES INSERTED INTO THE STRAINER AS DAMAGE TO THE O-RINGS MAY RESULT.**
7. **These** products are designed to operate on 20-105 PSIG supply line pressure. If inlet pressure is above 105 PSIG, a pressure regulator must be installed in the supply line. Any damage caused by reason of connecting these products to supply line pressures lower than 20 PSIG or higher than 105 PSIG is not covered by warranty.
8. **Check** stream height from bubbler. Stream height is factory set at 35 PSI. If supply pressure varies greatly from this, turn adjustment screw on the regulator (Item 7). Clockwise adjustment will raise stream height and counter-clockwise will lower stream height. For best adjustment stream should hit basin approximately 6-1/2" (165mm) from bubbler.

## TROUBLE SHOOTING AND MAINTENANCE

1. **Orifice Assy:** Mineral deposits on orifice can cause water flow to spurt or not regulate. Mineral deposits may be removed from orifice with a small round file not over 1/8" diameter or a small diameter wire.  
**CAUTION:** Do not file or cut orifice materials.
2. **Stream Regulator:** If orifice is free of material deposits, regulate flow according to instruction 8 stated above.
3. **Actuation of Quick Connect Water Fittings:** Cooler is provided with lead-free connectors which utilize an o-ring water seal. To remove tubing from the fitting, relieve water pressure, push in on the gray collar while pulling on the tubing (See Figure 1). To insert tubing, push tube straight into the fitting until it reaches a positive stop, approximately 3/4".

FIG. 7

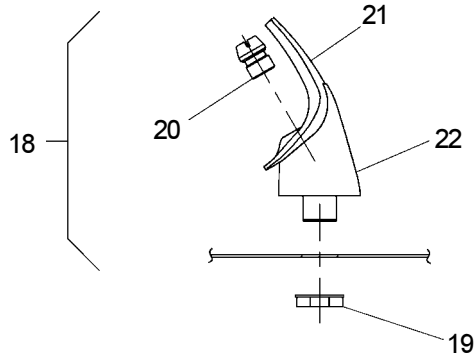
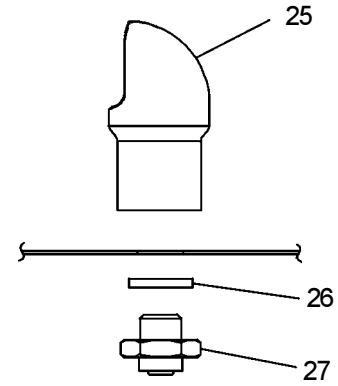
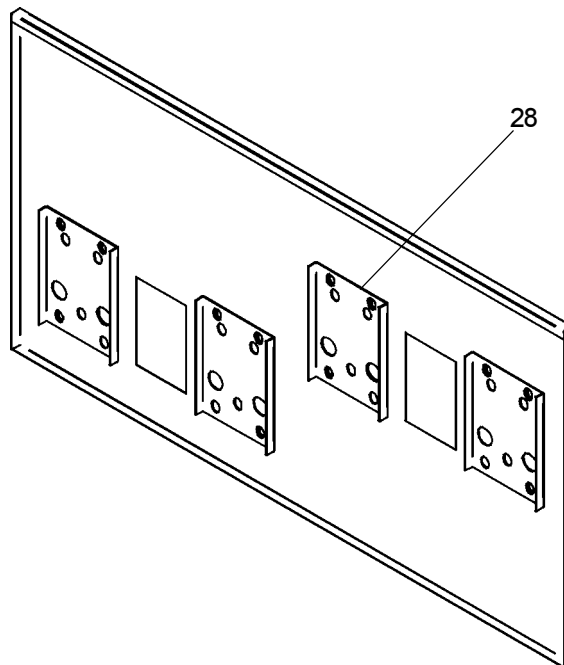

FIG. 8



NOTE: WHEN INSTALLING REPLACEMENT BUBBLER AND PEDESTAL, TIGHTEN NUT (ITEM 19) ONLY TO HOLD PARTS SNUG IN POSITION. **DO NOT OVER TIGHTEN.**

FIG. 9



**Installing back panel:** When installing back panel without mounting plate accessory, attach (4) channel braces as shown in Fig. 9. Remove the protective backing from the tape installed on the brace. Line up the corresponding holes in the brace and back panel and press firmly in place.

EDFPA17C\*A EDFPA17RAC\*A EDFPAVR17C\*A EDFPAVR17RAC\*A

PARTS LIST		
ITEM NO.	PART NO.	DESCRIPTION
1	21696C	BRACKET-PUSH BAR MTG.
2	21708C	PUSH BAR ASSY
3	112627543890	SCREW - #10-24 x .50 PHTC
4	21695C	LEVER - PUSH
5	50986C	HOLDER - REGULATOR
6	40045C	HEX NUT
7	61314C	REGULATOR
8	15005C	RETAINING NUT
9	75555C	CLIP
10	50198C	BUSHING - NYLON
11	70379C	ROD - PIVOT
12	70278C	ROD - PIVOT
13	70378C	ROD - PUSH
14	21705C	CLIP - PUSH ROD
15	70002C	SCREW - #10 X .50 HHSM
16	40206000	RETAINER
17	70023C	SET SCREW
18	56073C	BUBBLER ASSY
19	75580C	BUBBLER LOCKNUT
20	40322C	ORIFICE ASSY
21	56011C	HOUSING ASSEMBLY
22	55997C	PEDESTAL
23	28225C	BACK PANEL RH ADA
	28226C	BACK PANEL LH ADA
24	55001082	FTN BODY ASSY-SHORT
	55001083	FTN BODY ASSY-LONG
25	45392C	BUBBLER (VR MODEL ONLY)
26	100322740560	GASKET (VR MODEL ONLY)
27	15009C	BUBBLER-NIPPLE (VR MODEL ONLY)
28	28234C	BRACE-CHANNEL
29	55996C	STRAINER
30	56092C	POLY TUBING (CUT TO LENGTH)
NS	LK464	DRAIN
NS	27090C	BRACKET-HANGER PANEL

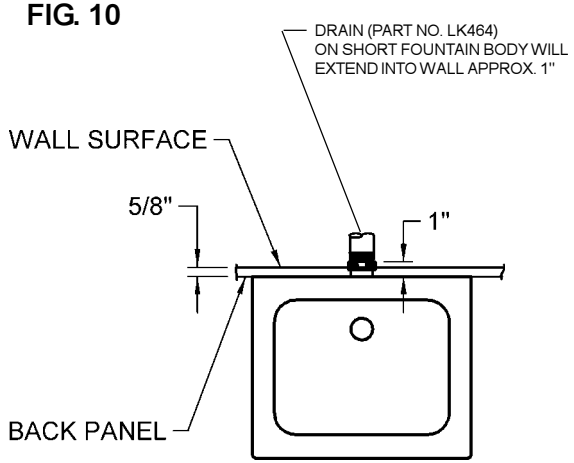

**FIG. 11**

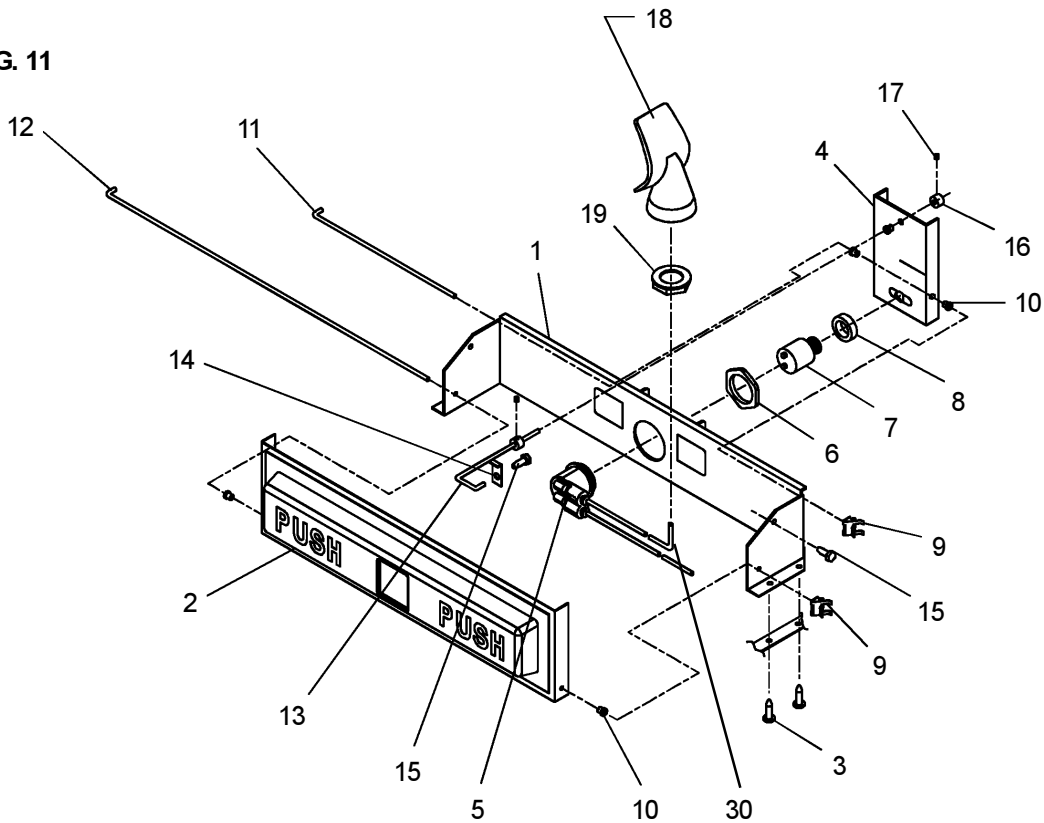

FOR PARTS, CONTACT YOUR LOCAL DISTRIBUTOR OR CALL 1.800.323.0620  
ELKAY MANUFACTURING COMPANY • 2222 CAMDEN COURT • OAK BROOK, IL 60523 • 630.574.8484