

ELKAY® SPECIFICATIONS

Wall Mount Water Coolers Barrier-Free Access (Adult & Child) ANSI/NSF61 Compliant Models EZ4, EZ8, EZS4, EZS8, EZSD and EZD

GENERAL

Self-contained, wall hung electric refrigerated water cooler. Chilling capacity of 50°F drinking water, based upon 80°F inlet water and 90°F ambient.

Models EZS4 and EZS8 have self-closing Easy-Touch Controls on front and both right and left sides.

Models EZ4 and EZ8 each have self-closing Easy-Touch Controls on the front only.

Model EZSD is non-refrigerated. Same as EZS8 without cooling system. (Requires outlet for power cord.)

All models have a hooded stream projector with Easy-Touch Controls that require less than 3 pounds of force to activate. Patented* valve with built-in flow regulator provide constant stream from 20 to 105 psi, water pressure. Bubbler orifice fully protected to meet all sanitary codes.

Non-pressurized stainless steel cooling tank is standard. Non-pressurized water tank is located after bubbler valve, so that tank is subject to line pressure only when Easy-Touch Control is pressed.

ADA COMPLIANT

These Water Coolers comply with the requirements of A.D.A. (Americans with Disabilities Act) when properly installed. Also meets the guidelines for children's environments providing the floor to orifice height is 30" or less and proper clear floor space is provided for parallel approach. (Based on Architectural and Transportation Barriers Compliance Board final ruling.) Check Local and State Codes.

NO LEAD DESIGN

These Water Coolers are certified to be lead-free as defined by the Safe Drinking Water Act. Elkay Water Coolers are manufactured with a waterway system utilizing copper components and completely lead-free materials. These waterways have no lead because all lead materials, such as leaded brass, have been removed. All joints are brazed using silver solder only. No lead solder is permitted. A strainer with an easily cleanable screen is provided to allow trapping and convenient removal of waterborne particulate of 140 microns and larger prior to their entry into the water cooler.

These water coolers are certified to **ANSI/NSF61**.

CAPACITIES CHART

Model Number	Base Rate	**GPH of 50°F Drinking Water			Rated Watts	Full Load Amps	Glass† Filler Option	Ship. Wt. Lbs.
		Room Temperature °F						
		70°F	80°F	90°F				
EZS4	4.0	5.0	4.4	4.0	325	3.7	Yes	56
EZS8	8.0	9.6	8.8	8.0	325	3.7	Yes	56
EZ4	4.0	5.0	4.4	4.0	325	3.7	Yes	56
EZ8	8.0	9.6	8.8	8.0	325	3.7	Yes	56
EZSD	-	-	-	-	-	-	Yes	18
EZD	-	-	-	-	-	-	Yes	18

**Based on 80°F inlet water temperature. †Glass filler available at extra cost. Requires factory preparation to receive glass filler.

Rated watts shown are based on operational (run) time, in accordance with A.R.I. Standard 1010 conditions. Specific applications will determine the actual watts consumed per hour. Watts consumed will be based on number of people served per hour (usage), ambient temperatures, and inlet water temperature.

COOLING SYSTEM

Motor Compressor: Hermetically sealed, reciprocating type, 115V, 60 Hz single phase. Sealed-in lifetime oil supply. Equipped with electric cord and three prong molded rubber plug (domestic models).

Condenser: Fan cooled, copper tube with aluminum fins. Fan motor is permanently lubricated.

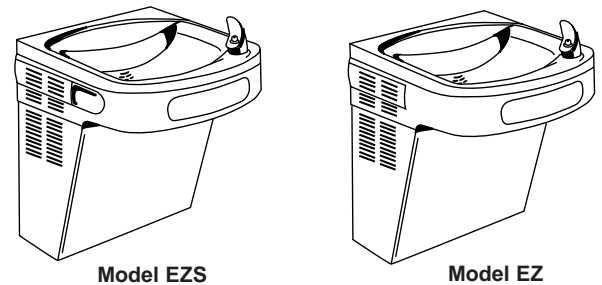

Cooling Unit: Combination tube-tank type. Self cleansing. Tube portion is continuous coil of copper tubing. Tank is stainless steel. Fully insulated with EPS foam which meets Underwriters Laboratories Inc. requirements for self-extinguishing material.

Refrigerant Control: Refrigerant HFC-134a is controlled by accurately calibrated capillary tube for positively trouble-free operation.

Temperature Control: Enclosed adjustable thermostat is factory pre-set. Requires no adjustment other than for altitude requirements. Easily accessible.

CONSTRUCTION

Frame: Galvanized structural steel chassis supports refrigeration system and fastens to wall. Provides increased structural integrity and rigidity to cooler.

Stainless Steel Basin: One piece polished to a uniform Elkay bright luster finish. Basin has integral drain grid, embossed bubbler pad. No exposed fasteners.

Exclusive Flexi-Guard® Safety Bubbler*: Innovative design utilizes an infused anti-microbial pliable polyester elastomer to prevent accidental mouth injuries. Flexes on impact, then returns to original position. Strong. Abrasion-resistant. Anti-sweat. Keyed in location to prevent rotation.

Upper Shroud: Contoured shock-absorbing, provides additional protection against accidental injury. No exposed fasteners.

Lower Shroud: One piece easy to remove and replace. Allows access to internal components from three sides.

Cabinet: Cabinet design allows for flush to wall mounting. No recess space is required.

Color Selection: Unless otherwise specified cabinet is two-tone gray on upper shroud with textured gray lower shroud. Stainless Steel lower shroud available at extra cost.

5 YEAR LIMITED WARRANTY on the refrigeration system of the unit. Electrical components and water system are warranted for 12 months from date of installation. Sample Certificate available on request.

Elkay Pressure-Type Water Coolers are designed to operate on 20 psi to 105 psi supply line pressure. If inlet pressure is above 105 psi, a pressure regulator must be installed in the supply line. Any damage caused by reason of connecting this product to supply line pressures lower than 20 psi or higher than 105 psi is not covered by the warranty.

STANDARDS



Elkay Electric Air Cooled Water Coolers are listed by Underwriters Laboratories Inc. and comply with both Canadian and U.S. requirements.



Rated in accordance with A.R.I. Standard 1010 and meets all known federal and state plumbing codes.

* Patent #4,481,971

In keeping with our policy of continuing product improvement, Elkay reserves the right to change product specifications without notice.

This specification describes an Elkay product with design, quality and functional benefits to the user. When making a comparison of other producers' offerings, be certain these features are not overlooked.

Wall Mount Water Coolers
Barrier-Free Access (Adult & Child)
ANSI/NSF61 Compliant
Models EZ4, EZ8, EZS4, EZS8, EZSD and EZD

ELKAY®
ROUGH-IN DIMENSIONS

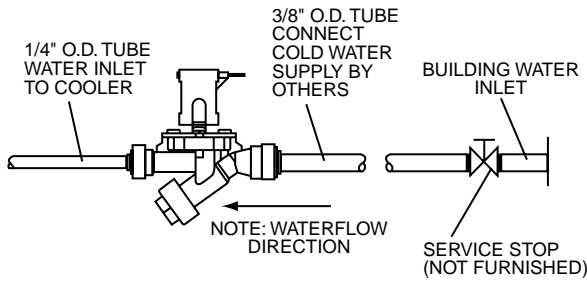

Open space rough-in design permits new installation or replacement of existing fountains and coolers with this Elkay cooler when rough-in is within the outline shown. When the cooler is mounted as shown the location available is from 15" to 21-11/16" from floor and 1-1/16" to 7-1/4" from the left of centerline. Space is also available from 21-11/16" to 24-5/8" from floor and 2-3/4" to 7-1/4" from the left of centerline. Additional space is also available from 24-5/8" to 26-11/16" from floor and 3-3/4" to 7-1/4" from the left of centerline. Connections approaching the limits of these areas may be restricted and should only be considered for use until after an examination of the cooler has been made.

IMPORTANT!
INSTALLER PLEASE NOTE:

This water cooler has been designed and built to provide water to the user which has not been altered by materials in the cooler waterways.

The grounding of electrical equipment such as telephone, computers, etc., to water lines is a common procedure. This grounding may be in the building but may also occur away from the building. This grounding can cause electrical feedback into a water cooler creating an electrolysis which creates a metallic taste or causes an increase in the metal content of the water. This condition is avoidable by installing the cooler using the proper materials as shown below.

NOTICE

This water cooler must be connected to the water supply using a dielectric coupling. The cooler is furnished with a non-metallic strainer which meets this requirement.

The drain trap which is provided by the installer should also be plastic to completely isolate the cooler from the building plumbing system.

OPERATION OF QUICK CONNECT FITTINGS

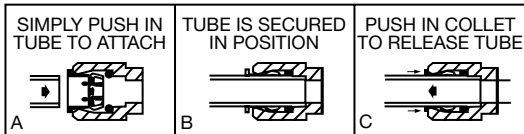

PUSHING TUBE IN BEFORE PULLING IT OUT HELPS TO RELEASE TUBE

FRONT VIEW

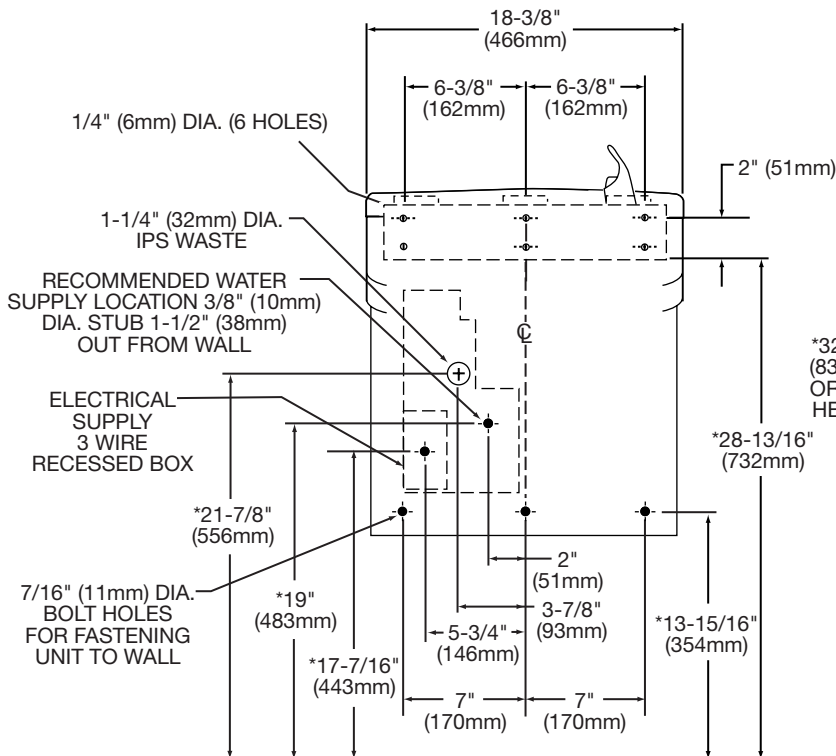

SIDE VIEW

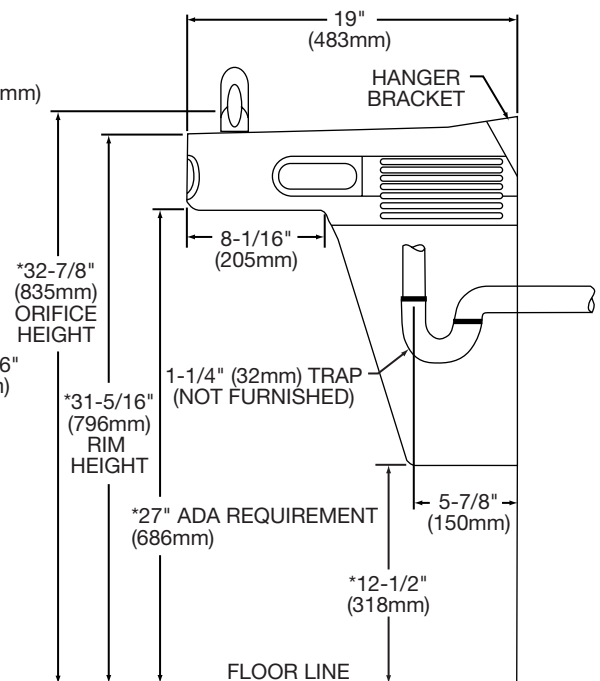

*Reduce height by 3 inches for installations used primarily by children ages 12 and younger. Shall also have a minimum clear floor space 30" (760mm) by 48" (1220mm).

NOTE: INSURE PROPER VENTILATION BY MAINTAINING 6" (152mm) CLEARANCE FROM CABINET LOUVERS TO WALL ON EACH SIDE OF COOLER.