

Installation Instructions

ER19-1C/2C TR419-1C Refrigeration Packages

NOTICE: This water cooler must be connected to the water supply using a dielectric coupling.

NOTE: It is important to insure proper ventilation. Allow a minimum clearance of 12 inches (305 mm) in front and 3 inches (76mm) in the rear of the unit. If unit is to be installed in an enclosure, allow the following clearances around unit - 1 inch (25mm) each side, 3 inches (76mm) in the rear, 3 inches (76mm) inches above wall.

This chiller has been designed for use with potable water and includes an o-ring seal on the drain plug. The fitting should be replaced if the unit is to be used with more aggressive fluids.

For use with photo processing applications, adjust cold control to warmer settings.

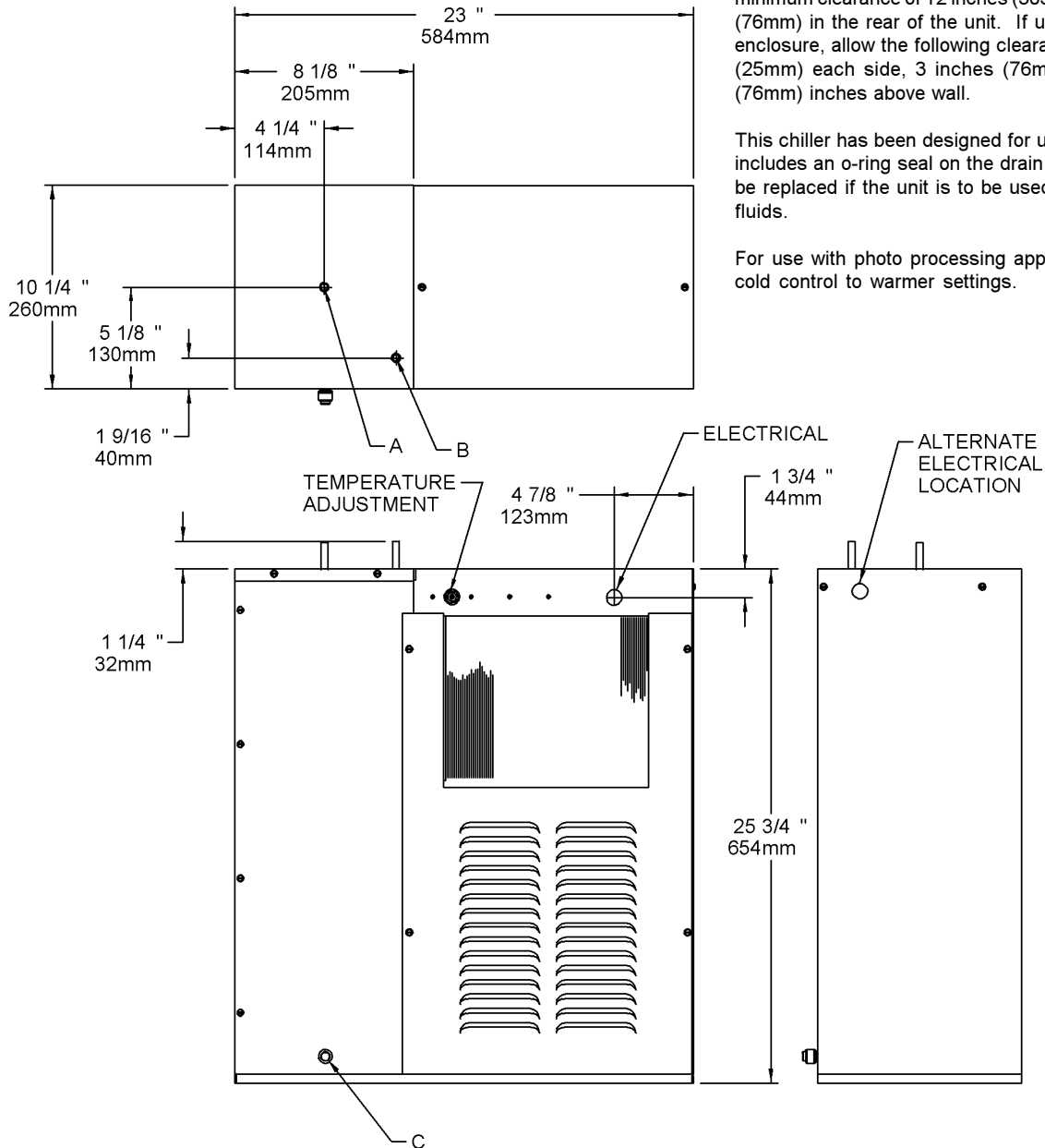

LEGEND

- A = 3/8" O.D. TUBE WATER OUT
- B = 3/8" O.D. TUBE WATER INLET
- C = 3/8" O.D. TUBE TANK DRAIN

ER19-1C/2C, TR419-1C

INSTALLATION

1. Potable water inlet and outlet are 3/8" (9 mm) O.D. tube located on top of unit. Contractor to supply connections as required.
2. Connecting lines to be of copper, thoroughly flushed to remove all foreign matter before being connected to cooler. If flushing does not remove all particles, a water strainer should be installed in supply line.
3. Connect cooler to building supply line with a shut-off valve and install a union connection between the valve and cooler.
4. Electrical: Make sure power supply is identical in voltage, cycle, and phase to that specified on cooler serial plate. Never wire compressor directly to the power supply.

START-UP

1. Open supply line valve.
2. Purge air from all water lines by operating bubbler valve of fountain.
3. Connect to electrical power.

TROUBLE SHOOTING & MAINTENANCE

Temperature Control: Factory set for 50° F water under normal conditions. To adjust water temperature, turn screw on Item No. 2 clockwise for colder, counter clockwise for warmer.

Ventilation: Cabinet louvers should be periodically cleaned with brush, air hose or vacuum cleaner. Excess dirt or poor ventilation can cause no cold water and compressor cycling on the compressor overload protector

Lubrication: Motors are lifetime lubricated.

| ITEMIZED PARTS LIST | | |
|---------------------|----------|-------------------------------|
| ITEM NO. | PART NO. | DESCRIPTION |
| 1 | 23089C | Terminal Box Cover |
| 2 | 35882C | Cold Control |
| 3 | 35895C | Cold Control (Freeze Protect) |
| 4 | 36072C | Fan Motor |
| 5 | 30502C | Fan Blade |
| 6 | 41991000 | Fan Bracket |
| 7 | 70018C | Fan Nut |
| 8 | 70009C | Motor Mounting Screw |
| 9 | 66628C | Condenser |
| 10 | 32817000 | Shroud |
| 11 | 35921C | Capacitor |
| 12* | 36074C | Compressor Serv Pak (115v) |
| 13 | 30812C | Overload |
| 14 | 30234C | Clip Compressor |
| 15 | 30233C | Overload Spring |
| 16 | 30235C | Terminal Cover |
| 17 | 36079C | Relay |
| 18 | 50196C | Grommet |
| 19 | 66625C | Evaporator Assy |
| 20 | 27957C | Insulation Box Cover |
| 21 | 70772C | Drain Plug |
| 22 | 27197C | Grill (Front) |
| 23 | 28176C | Base Assy |
| 24 | 28180C | Insulation Box Panel (Rear) |
| 25 | 23101C | End Panel |
| 26 | 23104C | Insulation Box (Front) |
| 27 | 28178C | Terminal Box |
| 28 | 66629C | Heat Exchanger |
| 29 | 35845C | Cap-Capacitor End |
| 30 | 35846C | Bracket-Capacitor |
| 31 | 30560C | Terminal Cover |
| 32 | 70274C | Compressor Mounting Sleeve |
| NS | 27198C | Grill (Rear) |
| NS | 66204C | Drier |

ER19-2C 220V, 50 HZ

| ITEM NO. | PART NO. | DESCRIPTION |
|----------|----------|---------------------|
| 4 | 36073C | Fan Motor |
| 11 | 35942C | Capacitor |
| 12* | 36075C | Compressor Serv Pak |
| 13 | 30813C | Overload |
| 17 | 35867C | Relay |

*INCLUDES RELAY & OVERLOAD. IF UNDER WARRANTY, REPLACE WITH SAME COMPRESSOR USED IN ORIGINAL ASSEMBLY.

NOTE: All correspondence pertaining to any of the above water cooler or orders for repair parts MUST include model number and serial number of cooler, name and part number of replacement part.

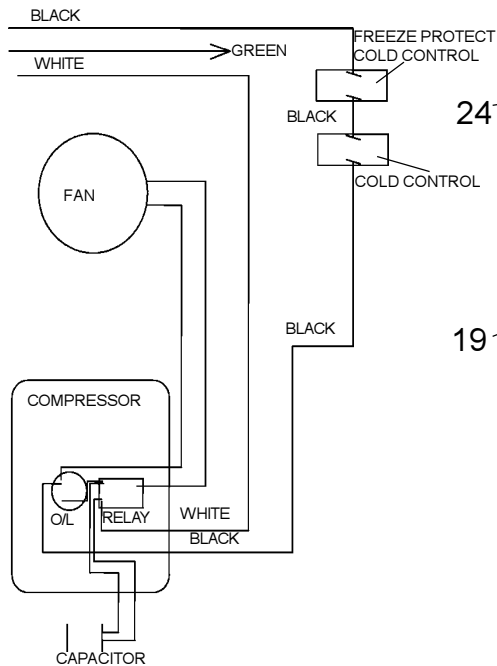

WIRING DIAGRAM

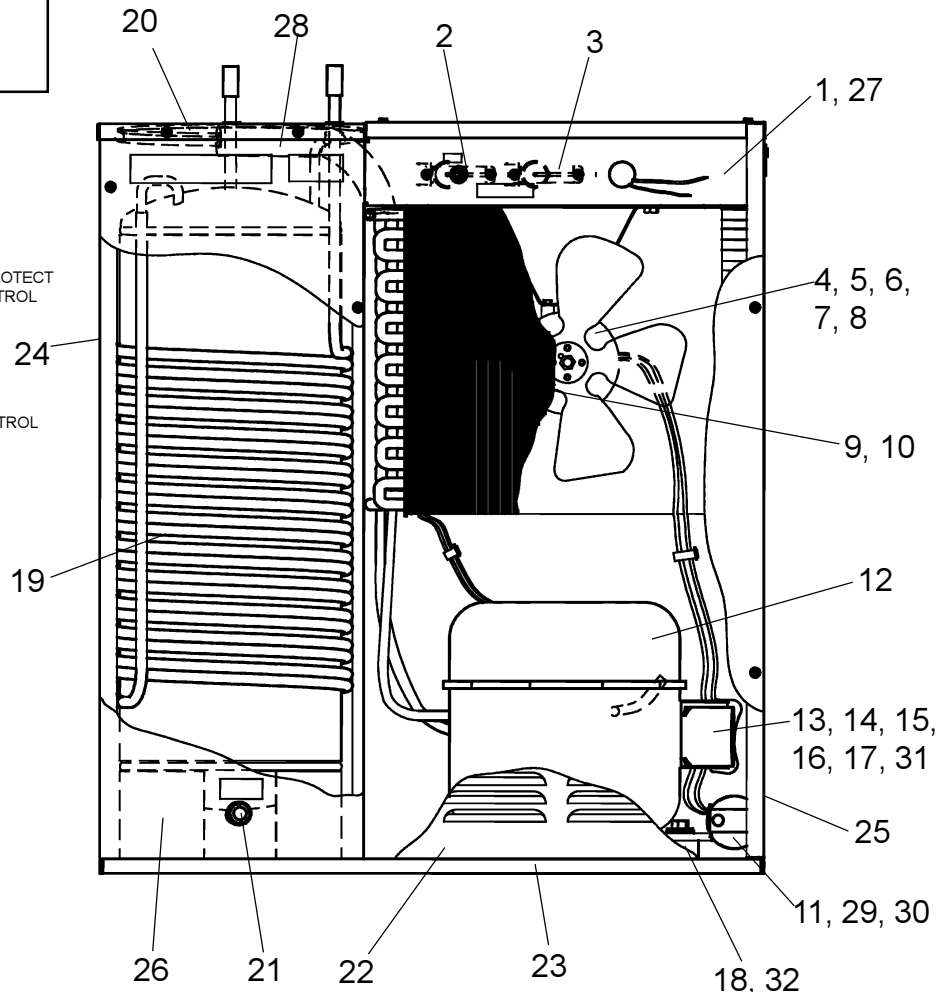

ELKAY MANUFACTURING COMPANY • 2222 CAMDEN COURT • OAK BROOK, IL 60523 • 630.574.8484
FOR PARTS, CONTACT YOUR LOCAL DISTRIBUTOR OR CALL 1.800.323.0620