

Installation Instructions

HRC32W

Refrigeration Package

INSTALLATION

- 1. This unit is intended for remote installation only.** It is important to insure proper ventilation. A minimum of 6 inches (152mm) to the front must be maintained, and 6 inches (152mm) to the rear of the unit.
- 2. This chiller has been designed for use with potable water** and includes an o-ring seal on the drain plug. This fitting should be replaced if the unit is to be used with more aggressive fluids.
- 3. Installer to provide air gap** at condenser water outlet to comply with local plumbing specifications.
- 4. Connecting lines to be made of copper.** Thoroughly flush all lines to remove all foreign matter before connecting to cooler. If flushing does not remove all particles, a water strainer should be installed in the supply line.
- 5. Connect cooler to building supply** with a shut-off valve and install a union connection between the valve and the cooler.
- 6. Electrical: Make sure power supply is identical** in voltage, cycle, and phase to that specified on cooler serial plate. Never wire the compressor directly to the power supply.

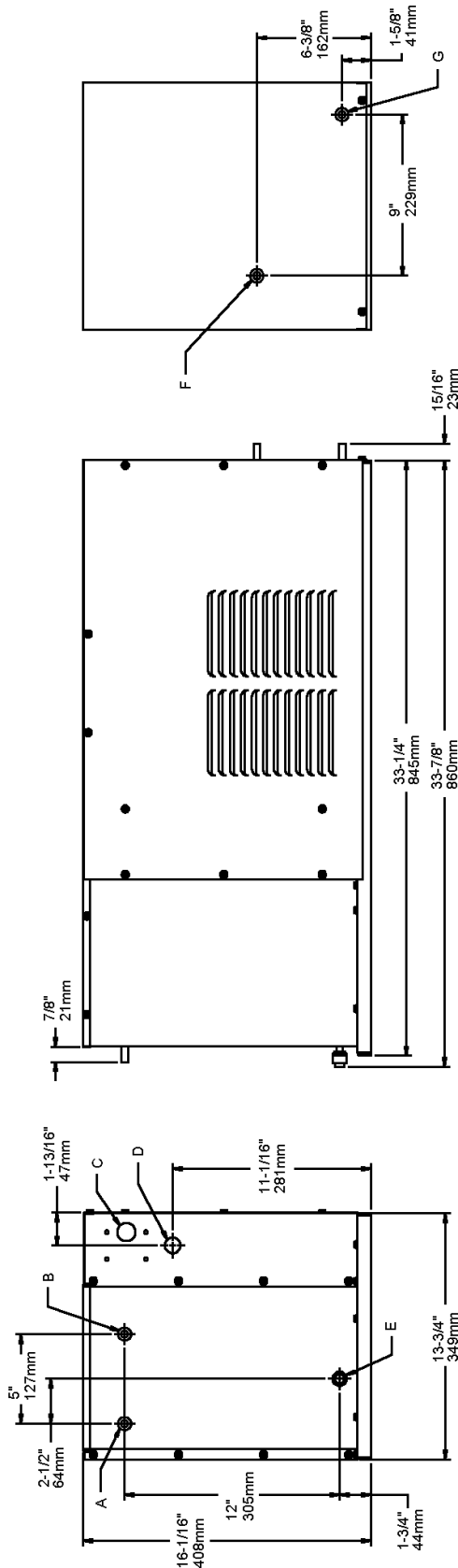

LEGEND

- A = 3/8" O.D. TUBE WATER INLET
- B = 3/8" O.D. TUBE WATER OUT
- C = TEMPERATURE ADJUSTMENT
- D = ELECTRICAL
- E = 3/8" O.D. TUBE TANK DRAIN
- F = 3/8" O.D. TUBE CONDENSER WATER OUTLET
- G = 3/8" O.D. TUBE CONDENSER WATER INLET

START-UP

PARTS LIST		
ITEM NO.	PART NO.	DESCRIPTION
1	23152C	BOX - INSULATION
2	26700C	BASE ASSY
3	23154C	PANEL
4	26702C	PANEL - FRONT
5	23158C	COVER - INSULATION BOX
6	23159C	BRACKET - CONDUIT
7	26701C	CABINET
8	34783005	WASHER - LOCK
9	35882C	CONTROL - COLD
10	66218C	CONDENSER ASSY
11	31723000	STRAINER
12	30440C	CAPACITOR
13	30768C	SOLENOID VALVE
14	43242004	CAPILLARY TUBE
*15	48000036	COMPRESSOR
16	30248C	OVERLOAD
17	48000070	GASKET - TERM COVER
18	48000067	OVERLOAD SPRING
19	48000069	BALE STRAP
20	48000068	COVER - TERMINAL
21	19037000	CLIP - COMPRESSOR MTG
22	100806740570	GROMMET - COMPRESSOR MTG
23	66216C	EVAPORATOR ASSY
24	70772C	EVAPORATOR DRAIN PLUG
25	31738002	DRIER
26	70020C	NUT
NS	26703C	PANEL - REAR

1. Open supply line valve.
2. Purge all air from all water lines by operating bubbler valve of fountain to which cooler is connected. A steady stream flow assures that all air is removed.
3. Rotate fan blade to assure proper clearance and free action.
4. Connect to proper electrical power.

IMPORTANT! INSTALLER PLEASE NOTE:

The grounding of electrical equipment such as telephone, computers, etc., to water lines is a common procedure. This grounding may be in the building, or may occur away from the building. This grounding can cause electrical feedback into a water chiller, creating an electrolysis which causes a metallic taste or an increase in the metal content of the water. This condition is avoidable by using the proper materials indicated below. Drain fittings which are provided by the installer should be plastic to electrically isolate the chiller from the building plumbing system.

TROUBLE SHOOTING & MAINTENANCE

Temperature Control: Factory set for 50°F water (± 5°) under normal conditions. For colder water, adjust screw on item no. 9 clockwise.

Ventilation: Cabinet louvers and condenser fins should be periodically cleaned with a brush, air hose, or vacuum cleaner. Excess dirt or poor ventilation can cause no cold water and compressor cycling on the overload protector.

Lubrication: Motors are lifetime lubricated.

Actuation of Quick Connect Water Fittings: Cooler is provided with lead-free plug which utilizes an o-ring seal. To remove plug from cooler, relieve water pressure, pull the collar towards the fitting and pull the fitting off the tube. To install plug, push fitting straight onto tubing until it reaches a positive stop, approximately 3/4".

*INCLUDES RELAY & OVERLOAD. IF UNDER WARRANTY REPLACE WITH SAME COMPRESSOR USED IN ORIGINAL ASSEMBLY.

NOTE: ALL CORRESPONDENCE PERTAINING TO ANY OF THE ABOVE WATER COOLERS OR ORDERS FOR REPAIR PARTS **MUST** INCLUDE MODEL NO. AND SERIAL NO. OF COOLER, NAME AND PART NO. OF REPLACEMENT PART.

NOTE: FOR USE WITH PHOTO PROCESSING APPLICATIONS, ADJUST THERMOSTAT TO WARMER SETTINGS.

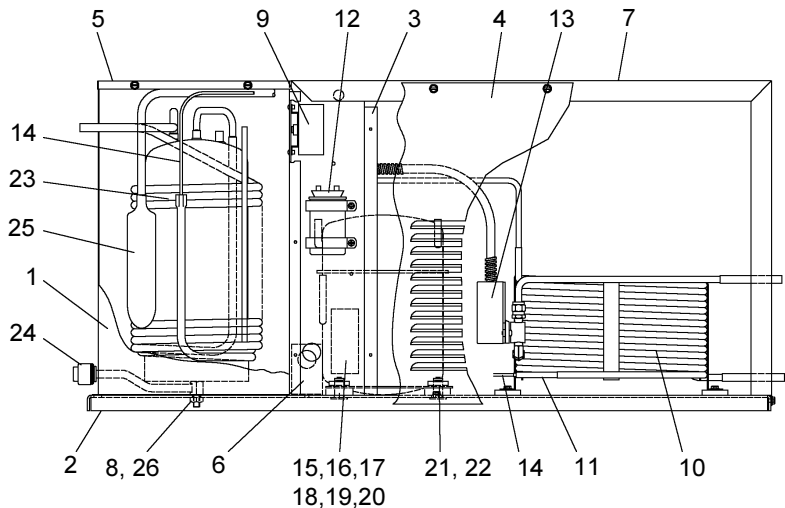

WIRING DIAGRAM

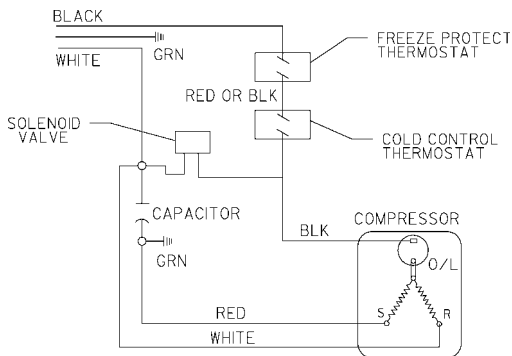

OPERATION OF QUICK CONNECT FITTINGS

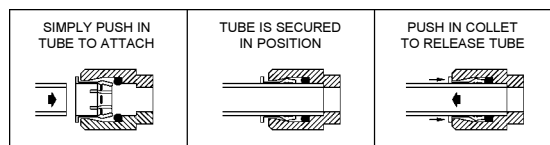

PUSHING TUBE IN BEFORE PULLING IT OUT HELPS TO RELEASE TUBE