

# Installation Instructions

## HRC30-1B HRC30-50-2B Refrigeration Packages

**NOTICE:** This water cooler must be connected to the water supply using a dielectric coupling.

### IMPORTANT! INSTALLER PLEASE NOTE.

The grounding of electrical equipment such as telephone, computers, etc., to water lines is a common procedure. This grounding may be in the building, or may occur away from the building. This grounding can cause electrical feedback into a water chiller, creating an electrolysis which causes a metallic taste or an increase in the metal content of the water. This condition is avoidable by using the proper materials indicated below.

### INSTALLATION

1. This unit is intended for remote installation only. It is important to insure proper ventilation. A minimum of 6 inches (152mm) to the front must be maintained, and 6 inches (152mm) to the rear of the unit.
2. This chiller has been designed for use with potable water and includes an o-ring seal on the drain plug. This fitting should be replaced if the unit is to be used with more aggressive fluids.
3. Installer to provide air gap at condenser water outlet to comply with local plumbing specifications.
4. Connecting lines to be made of copper. Thoroughly flush all lines to remove all foreign matter before connecting to cooler. If flushing does not remove all particles, a water strainer should be installed in the supply line.
5. Connect cooler to building supply with a shut-off valve and install a union connection between the valve and the cooler.
6. Electrical: Make sure power supply is identical in voltage, cycle, and phase to that specified on cooler serial plate. Never wire the compressor directly to the power supply.
7. For use with photo processing applications, adjust thermostat to warmer settings.

### START UP

1. Open supply line valve.
2. Purge all air from all water lines by operating bubbler valve of fountain to which cooler is connected. A steady stream assures that all air is removed.
3. Rotate fan blade to assure proper clearance and free action.
4. Connect to proper electrical power.

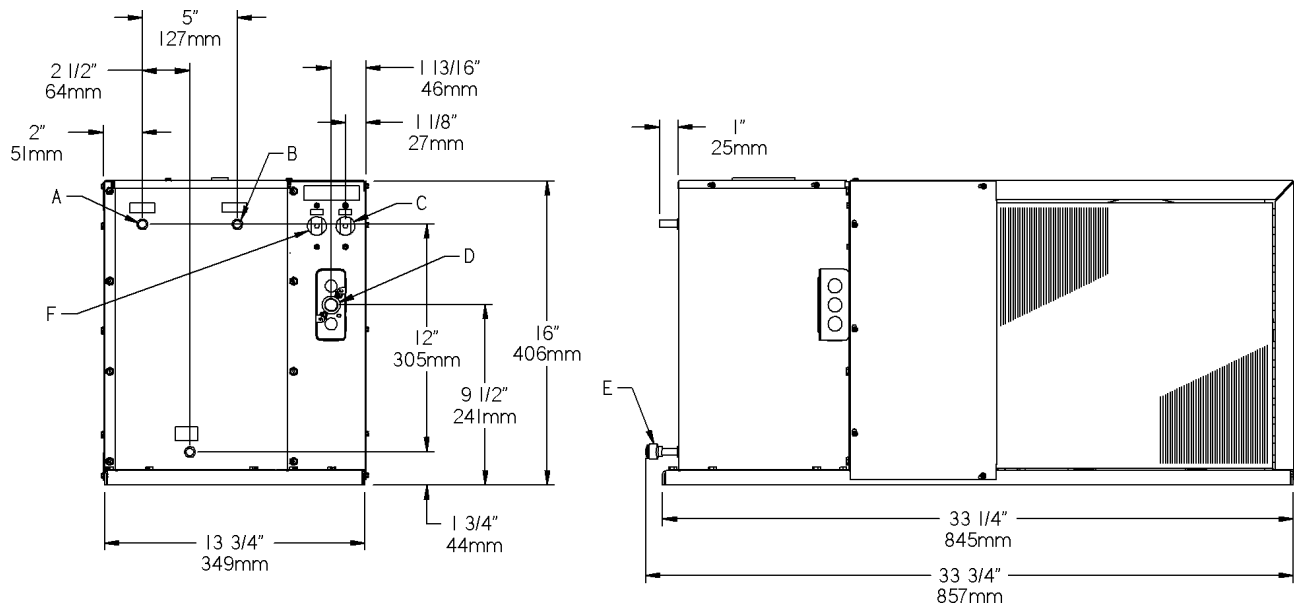

### LEGEND

A = 3/8" O.D. TUBE WATER INLET

C = TEMPERATURE ADJUSTMENT

E = 3/8" O.D. TUBE TANK DRAIN

B = 3/8" O.D. TUBE WATER OUTLET

D = ELECTRICAL

F = FREEZE CONTROL

### TROUBLE SHOOTING AND MAINTENANCE

ITEMIZED PARTS LIST		
ITEM NO.	PART NO.	DESCRIPTION
1	28165C	Box - Insulation
2	28218C	Base Assy
3	28166C	Panel
4	28167C	Panel - Front
5	23158C	Cover - Insulation Box
6	27702C	Cabinet
7	35882C	Control - Cold
8	35792C	Fan Motor
9	31180C	Fan Blade
10	31181C	Fan Bracket
11	66620C	Condenser
12	66621C	Drier
14	36045C	Overload Cover
15	35984C	Overload
16	35989C	Gasket (Terminal Cover)
17	35988C	Overload Spring
18	35990C	Bale Strap
20	30040C	Electrical Box Cover
21	50196C	Grommet
22	66624C	Evaporator Assy
23	70772C	Drain Plug
24	66623C	Heat Exchanger
25	70020C	Nut
26	34783005	Washer - Lock
27	28408C	Panel - Rear
28	30039C	Electrical Box
29	70274C	Compressor Sleeve
30	36034C	CSIR Box Assy
*31	35985C	Compr. Service Pak
32	35895C	Freeze Control

**Temperature Control:** Factory set for 50°F water under normal conditions. To adjust water temperature, turn screw on Item No. 7 clockwise for colder, counter clockwise for warmer.

**Ventilation:** Cabinet louvers and condenser fins should be periodically cleaned with a brush, air hose, or vacuum cleaner. Excess dirt or poor ventilation can cause no cold water and compressor cycling on the overload protector.

**Lubrication:** Motors are lifetime lubricated.

**Actuation of Quick Connect Water Fittings:** Cooler is provided with lead-free plug which utilizes an o-ring seal. To remove plug from cooler, relieve water pressure, pull the collar towards the fitting and pull the fitting off the tube. To install plug, push fitting straight onto tubing until it reaches a positive stop, approximately 3/4".

#### OPERATION OF QUICK CONNECT FITTINGS

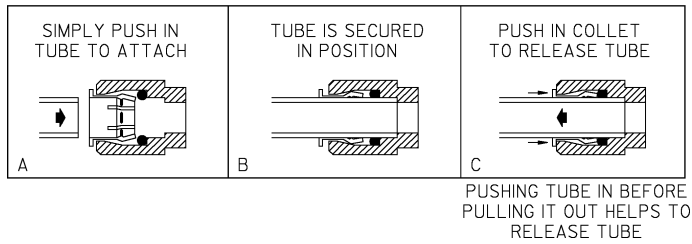

HRC30-2B 220V/50Hz

ITEM NO.	PART NO.	DESCRIPTION
8	35793C	Fan Motor
15	36059C	Overload
17	36055C	Overload Spring
30	36061C	CSIR Box Assy
*31	36060C	Compr. Service Pak
32	35895C	Freeze Control

\*INCLUDES COMPRESSOR, OVERLOAD & CSIR BOX ASSEMBLY. IF UNDER WARRANTY, REPLACE WITH SAME COMPRESSOR USED IN ORIGINAL ASSEMBLY. NOTE: All correspondence pertaining to any of the above water cooler or orders for repair parts MUST include model number and serial number of cooler, name and part number of replacement part.

