

With FLEXI-GUARD®

Installation/Care/Use Manual

USES HFC-134A REFRIGERANT

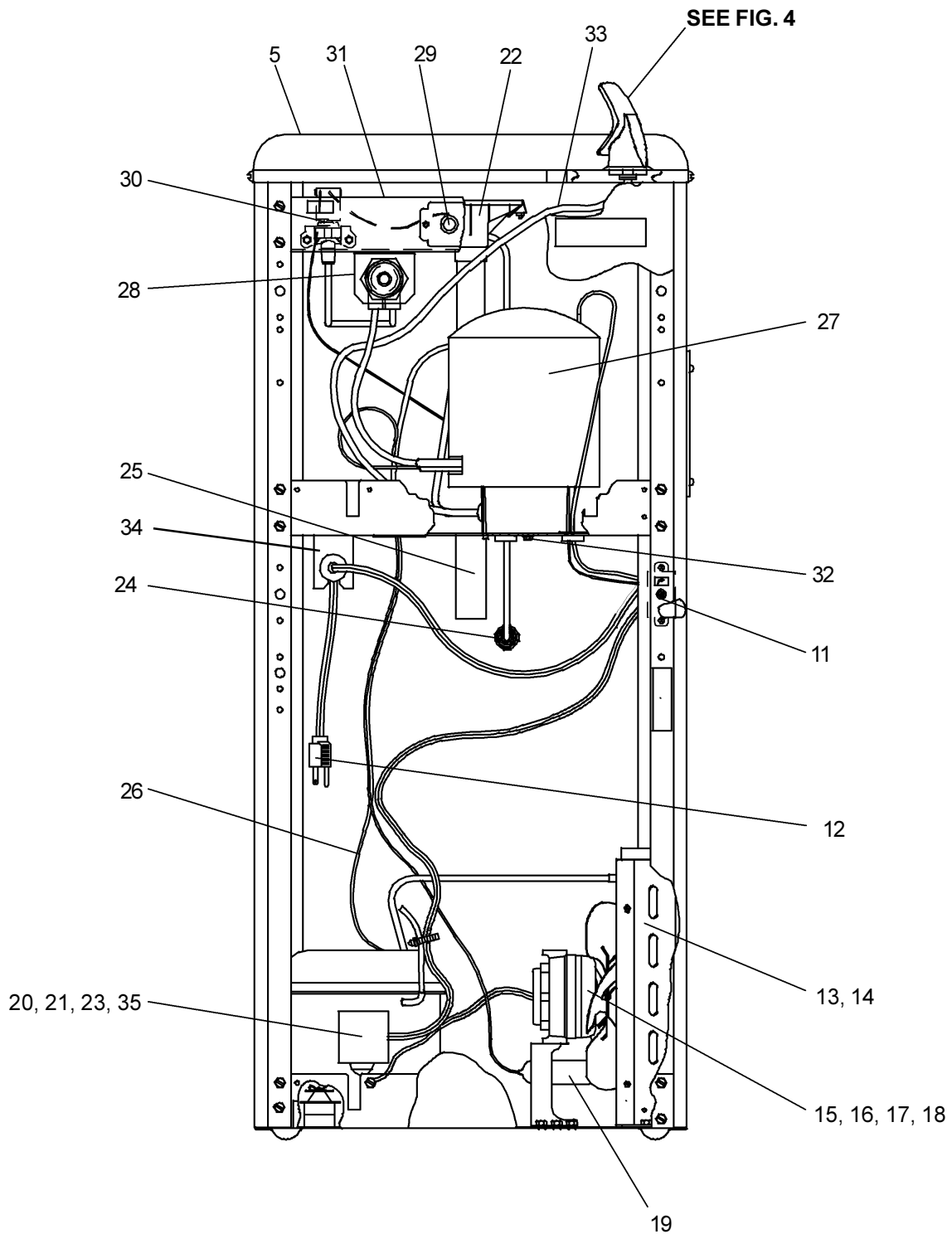

FIG. 1

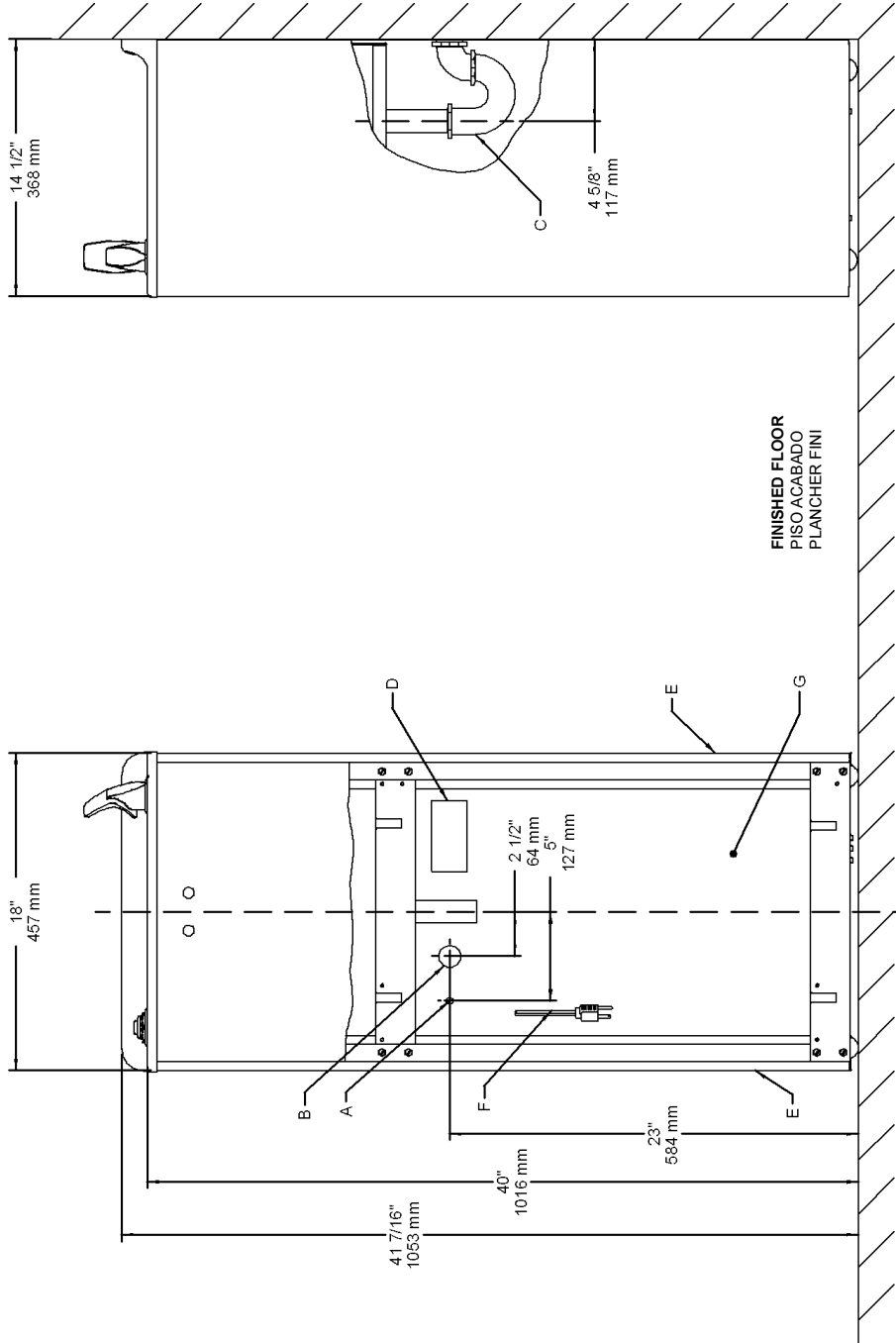

FIG. 2

- LEGEND/LEYENDA/LÉGENDE**
- A = RECOMMENDED WATER SUPPLY LOCATION 3/8 O.D. UNPLATED COPPER TUBE CONNECT STUB 1-1/2 IN. (38mm) OUT FROM WALL SHUT OFF BY OTHERS**
SE RECOMIENDA UBICAR EL TUBO CORTO DE CONEXIÓN AL TUBO DE COBRE SIN CHAPAR DE 3/8" DE DIÁM. EXT. A 1-1/2" (38mm) FUERA DE LA LLAVE DE PASO EN LA PARED COLOCADA POR TERCEROS.
EMPLACEMENT RECOMMANDÉ D'ALIMENTATION EN EAU PAR TUBE EN CUIVRE NON PLAQUÉ DE 3/8 PO. (9.5 mm) D.E. CONNECTANT UNE TUYAUTERIE DE 1-1/2 PO. (38mm) DEPUIS LE ROBINET D'ARRÊT FOURNI PAR D'AUTRES.
 - B = RECOMMENDED LOCATION FOR WASTE OUTLET 1-1/4" O.D. DRAIN**
UBICACIÓN RECOMENDADA PARA EL DRENAJE DE SALIDA DE AGUA, DE 1 1/4" DE DIÁMETRO.
EMPLACEMENT RECOMMANDÉ POUR LE DRAIN DE D.E. 1-1/4" DE SORTIE D'EAU.
 - C = 1-1/4" TRAP NOT FURNISHED****
PURGADOR DE 1 1/4" NO PROPORCIONADO**
SIPHON 1-1/4" NON FOURNI**
 - D = ELECTRICAL OUTLET LOCATION**
UBICACIÓN DE LA TOMA DE ELECTRICIDAD
EMPLACEMENT DE LA PRISE DE COURANT
 - E = INSURE PROPER VENTILATION BY MAINTAINING 4" (102mm) (MIN.) CLEARANCE FROM CABINET LOUVERS TO WALL.**
ASEGURE UNA VENTILACIÓN ADECUADA MANTENIENDO UN ESPACIO E 4" (102mm) (MÍN.) DE HOLGURA ENTRE LA REJILLA DE VENTILACIÓN DEL MUEBLE Y LA PARED
ASSUREZ-VOUS UNE BONNE VENTILATION EN GARDANT 4" (102mm) (MIN.) ENTRE LES ÉVÉNENTS DE L'ENCEINTE ET LE MUR.
 - F = POWER CORD 4 FEET (1219mm) LONG**
CABLE ELÉCTRICO DE 4 PIE (1219mm), DE LARGO
CORDON D'ALIMENTATION 4' (1219mm)
 - G = ALT. ELECTRICAL OUTLET LOCATION**
UBICACIÓN ALT. DE LA TOMA DE ELECTRICIDAD
EMPLACEMENT ALTERNATIF DE LA PRISE DE COURANT

SENSOR RANGE ADJUSTMENT: The electronic sensor used in this cooler is factory pre-set for a "visual" range of 36 inches (914 mm). If actual range varies greatly from this or a different setting is desired, follow the range adjustment procedure below:

- A. Remove front panel of cooler.
- B. Using a small tip screwdriver, rotate range adjustment screw clockwise to increase range and counterclockwise to decrease range (See Fig. 3).

CAUTION: Complete range of sensor (24-46 inches/610-1168mm) is only one turn of the adjusting screw.

- C. Replace front panel.

SENSOR CONTROL: If sensor fails to operate valve mechanism or operates erratically, check the following.

- A. Ensure there are no obstructions within a 40 inch (1016mm) radius in front of cooler.
- B. Check wire connections at the solenoid valve and sensor. **CAUTION:** Make sure unit is unplugged before checking any wiring.
- C. Ensure proper operation of solenoid valve. If there is an audible clicking sound yet no water flows, look for an obstruction in the valve itself or elsewhere in the water supply line.

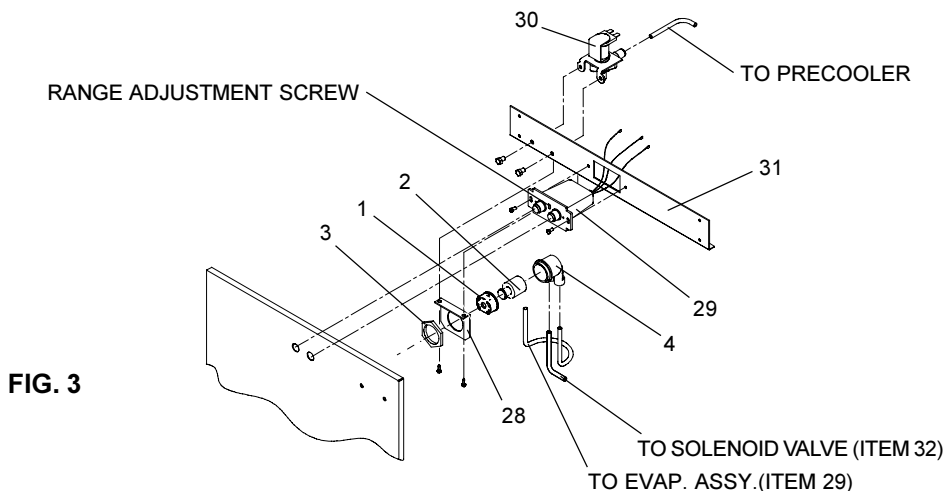
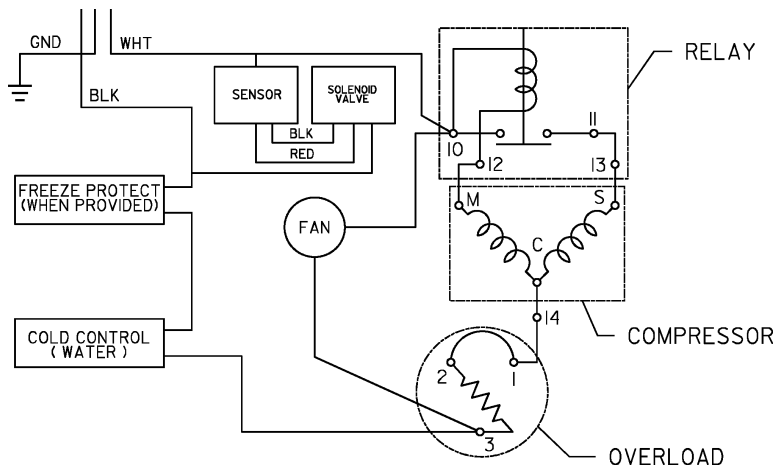

FIG. 3

WIRING DIAGRAM

This Drawing is merely for illustrating the components of the electrical system.



NOTE:
WHEN INSTALLING REPLACEMENT BUBBLER AND PEDESTAL, TIGHTEN NUT (ITEM 10) ONLY TO HOLD PARTS SNUG IN POSITION. DO NOT OVER TIGHTEN.

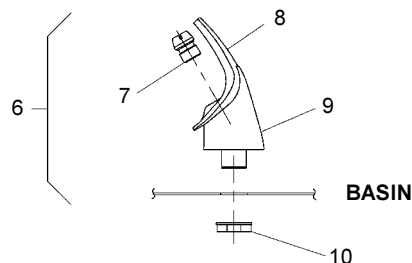

FIG. 4

PARTS LIST 115V

ITEM NO.	PART NO.	DESCRIPTION
1	56082C	Regulator Retaining Nut
2	61313C	Regulator
3	40045C	Hex Nut
4	50986C	Regulator Holder
5	27316C	Basin
6	56073C	Bubbler Assembly
7	40322C	Orifice Assembly
8	56011C	Housing Assembly
9	55997C	Pedestal
10	75580C	Bubbler Locknut
11	31513C	Cold Control
12	35890C	Power Cord
13	66417C	Condenser
14	21516C	Fan Shroud
15	31490C	Fan Motor
16	30664C	Fan Blade
17	20239C	Fan Bracket
18	70018C	Fan Blade Nut
19	66202C	Drier
20	35762C	Compressor Serv. Pak
21	31027C	Overload/Relay Assy.
22*	50368C	Receptor-Drain
23	194243901550	Electrical Shield
24	55996C	Strainer
25	45702C	Tailpipe Assy
26	66229C	Heat Exchanger
27	66505C	Evaporator
28	27278C	Regulator Bracket
29	31516C	Sensor (clear)
30	35891C	Solenoid Valve Assembly
31	27279C	Cross Brace
32	75568C	Screw-Evaporator Mtg
33	56092C	Poly Tubing (Cut To Length)
34	27961C	Brkt-Strain Relief
35	31797C	Relay Cover

*INCLUDES RELAY & OVERLOAD. IF UNDER WARRANTY, REPLACE WITH SAME COMPRESSOR USED IN ORIGINAL ASSEMBLY.
 NOTE: All correspondence pertaining to any of the above water coolers or orders for repair parts MUST include Model No. and Serial No. of cooler, name and part number of replacement part.

COLOR TABLE	LEFT PANEL	RIGHT PANEL	FRONT PANEL
Gray Beige	20622C	20623C	27272C
Almond	21460C	21461C	27273C
Stainless Steel	20624C	20625C	27270C
Sandalwood	21458C	21459C	27274C
Granite	27165C	27168C	27271C
Light Gray	27166C	27169C	27275C