

Installation/Care/Use Manual

EFRP8C & EFRPC8C

Refrigerated Fountains with FLEXI-GUARD®

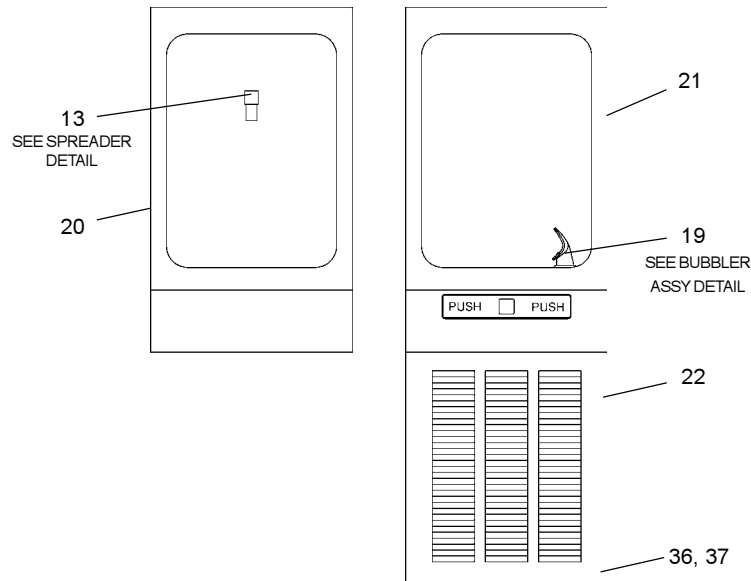

Installer

To assure you install this model easily and correctly, PLEASE READ THESE SIMPLE INSTRUCTIONS BEFORE STARTING THE INSTALLATION. CHECK YOUR INSTALLATION FOR COMPLIANCE WITH PLUMBING, ELECTRICAL AND OTHER APPLICABLE CODES. After installation, leave these instructions inside the fountain for future reference.

IMPORTANT

ALL SERVICE TO BE PERFORMED BY AN AUTHORIZED SERVICE PERSON

IMPORTANT! INSTALLER PLEASE NOTE.

THE GROUNDING OF ELECTRICAL EQUIPMENT SUCH AS TELEPHONE, COMPUTERS, ETC. TO WATER LINES IS A COMMON PROCEDURE. THIS GROUNDING MAY BE IN THE BUILDING OR MAY OCCUR AWAY FROM THE BUILDING. THIS GROUNDING CAN CAUSE ELECTRICAL FEEDBACK INTO A FOUNTAIN, CREATING AN ELECTROLYSIS WHICH CAUSES A METALLIC TASTE OR AN INCREASE IN THE METAL CONTENT OF THE WATER. THIS CONDITION IS AVOIDABLE BY USING THE PROPER MATERIALS AS INDICATED. ANY DRAIN FITTINGS PROVIDED BY THE INSTALLER SHOULD BE MADE OF PLASTIC TO ELECTRICALLY ISOLATE THE FOUNTAIN FROM THE BUILDING PLUMBING SYSTEM.

INSTALLATION INSTRUCTIONS

1. **Wall should already be framed for the fountain using dimensions shown in Fig. 1.** Shown dimensions pertain to installation location. (Framing shown for reference only).
2. **Fasten mounting box or boxes into wall cutout(s)** using bolts or screws (not provided).
3. **Mount fountain body (and cuspidor when applicable)** on mounting box. Screws and clips are provided for fastening fountain body to box.
4. **Remove strainer and the 3/8" O.D. tube that is inserted in it from the refrigeration package.** Install a 1/4 union (2 provided) on both the inlet and outlet line of the refrigeration package by pushing the tubes straight into fittings until they reach a positive stop, approximately 3/4". (See Fig. 3) **DO NOT SOLDER TUBES INSERTED INTO THE STRAINER AS DAMAGE TO THE O-RINGS MAY RESULT.**
5. **Place refrigeration package inside mounting box and connect the chiller inlet line** with the tube coming from the regulator holder (See Page 4) and connect the chiller outlet line with line coming from the bubbler.
6. **On cuspidor models, connect 1/4 tube coiled in fountain to spreader.** (See Page 4)
7. **Water supply is 3/8" O.D. and waste tailpiece(s) are 1-1/4" O.D.** Contractor is to supply waste trap(s) and service stop valve in accordance with local codes.
8. **Connecting lines to be unplated copper and thoroughly flushed** to remove all foreign matter before connecting to fountain assembly.
9. **Connect the fountain to supply line** by installing a union between the supply and fountain.
10. **Electrical: Insure power supply is identical in voltage, cycle, and phase** to that specified on the refrigeration package serial plate. Never wire compressor directly to the power supply.
11. **Turn water supply on and check thoroughly for leaks.**
12. **Release air from tank by depressing push bar;** a steady stream of water assures all air is removed.
13. **Re-check for leaks.**
14. **Stream height is factory set at 35 PSI.** If supply pressure varies greatly from this, turn adjustment screw on regulator (item 24). Clockwise adjustment will raise the stream height and counter-clockwise adjustment will lower stream height. For best adjustment, stream should hit basin approximately 6-1/2" from the bubbler.
15. **Rotate fan blade on refrigeration package** to insure proper clearance and free fan action.
16. **Connect power supply.**
17. **Install grill using #8 x 1.00" (25mm) PH screws and small clips provided.**

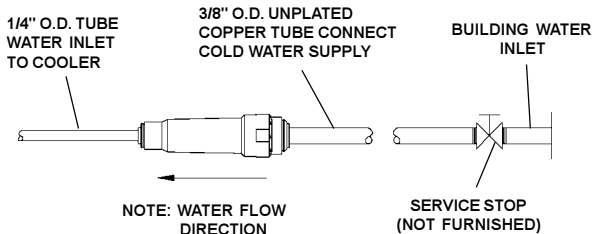
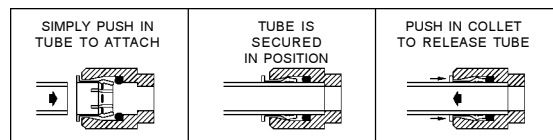

FIG. 2

OPERATION OF QUICK CONNECT FITTINGS



PUSHING TUBE IN BEFORE PULLING IT OUT HELPS TO RELEASE TUBE

FIG. 3

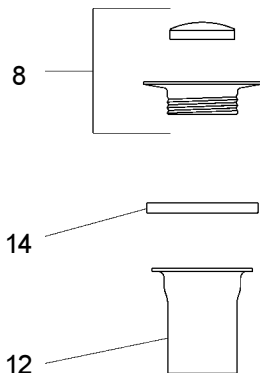

CUSPIDOR DRAIN

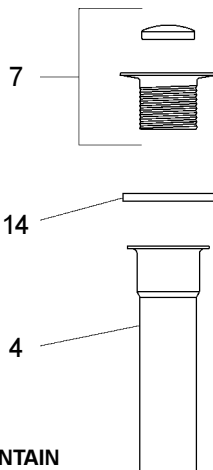

FOUNTAIN DRAIN

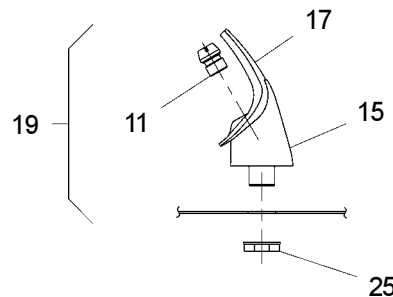

NOTE:
WHEN INSTALLING REPLACEMENT BUBBLER AND PEDESTAL, TIGHTEN NUT (ITEM 25) ONLY TO HOLD PARTS SNUG IN POSITION. DO NOT OVER TIGHTEN.

BUBBLER ASSY

EFRP8C & EFRPC8C

PARTS LIST

ITEM NO.	PART NO.	DESCRIPTION
1	15005C	NUT - RETAINING
2	21705C	CLIP - PUSH ROD
3	21708C	PUSH BAR ASSY
4	20397C	TAILPIPE (FOUNTAIN)
5	22911C	BRKT - LEVER PUSH
6	22912C	BRKT - PUSH BAR MTG
7	40575C	STRAINER/FERRULE ASSY (FTN)
8	45366C	STRAINER/FERRULE ASSY (CUSP)
9	40045C	HEX NUT - UNPLTD
10	40206000	RETAINER
11	40322C	ORIFICE ASSY
12	40572C	TAILPIPE (CUSPIDOR)
13	40624C	HEAD-SPREADER
14	50074C	GASKET - TAILPIPE
15	55997C	PEDESTAL
16	50198C	BUSHING - SNAP
17	56011C	HOUSING ASSY
18	50986C	HOLDER - REGULATOR
19	56073C	BUBBLER ASSY
20	55000857	CUSPIDOR
21	55001086	FOUNTAIN
22	55001080	GRILL EFRP
23	61314C	REGULATOR - W/GREEN SPRING
24	70002C	SCREW-#10 X .50 HHSM
25	75580C	NUT - 3/8-18 LKNT
26	70018C	NUT 1/4-20 HEX
27	70278C	ROD - SUPPORT
28	70378C	ROD - PUSH
29	55996C	STRAINER
30	70682C	TEE - 1/4
31	70920C	ROD - PIVOT
32	70971C	ELBOW 90 DEGREES-TUBE TO
33	70977C	NUT - LOCK 1/2 CONDUIT
34	75555C	CLIP - .125 STUD LOCK
35	70683C	UNION - 1/4
36	74070030	SCREW - #8 x 1.00 PH
37	74070032	SPEED NUT - #8
NS	MB23A	MOUNTING BOX - FOUNTAIN
NS	MB24	MOUNTING BOX - CUSPIDOR

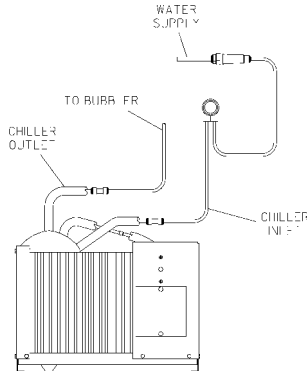

EFRP8C TUBE ROUTINGS

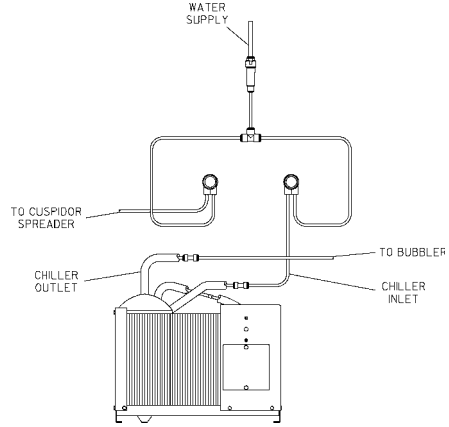

EFRPC8C TUBE ROUTINGS

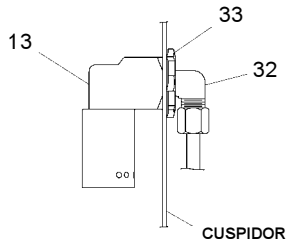

SPREADER DETAIL

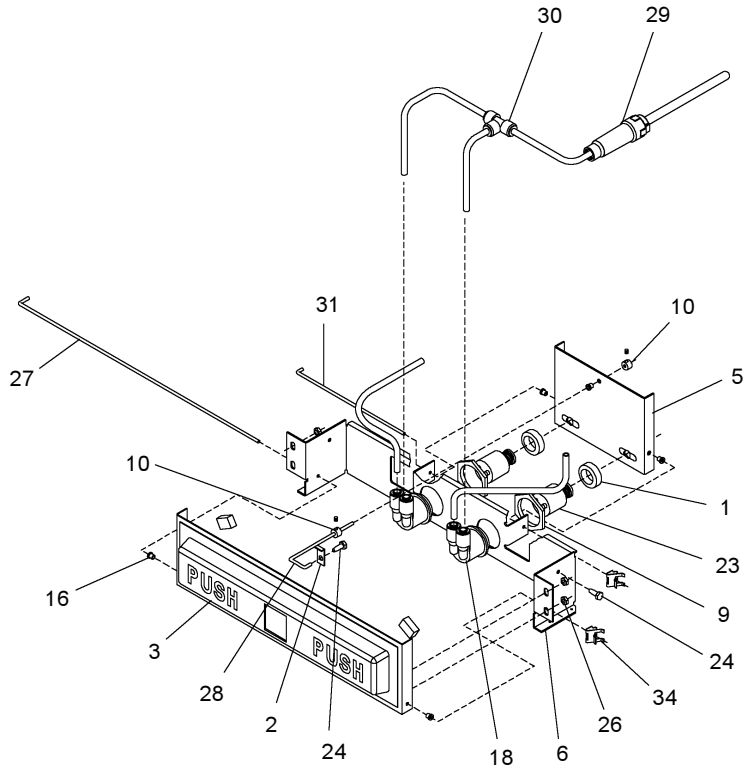

FOR PARTS, CONTACT YOUR LOCAL DISTRIBUTOR OR CALL 1.800.323.0620
 ELKAY MANUFACTURING COMPANY • 2222 CAMDEN COURT • OAK BROOK, IL 60523 • 630.574.8484