

Installation/Care/Use Manual

SwirlFlo® Refrigerated Fountains with FLEXI-GUARD®

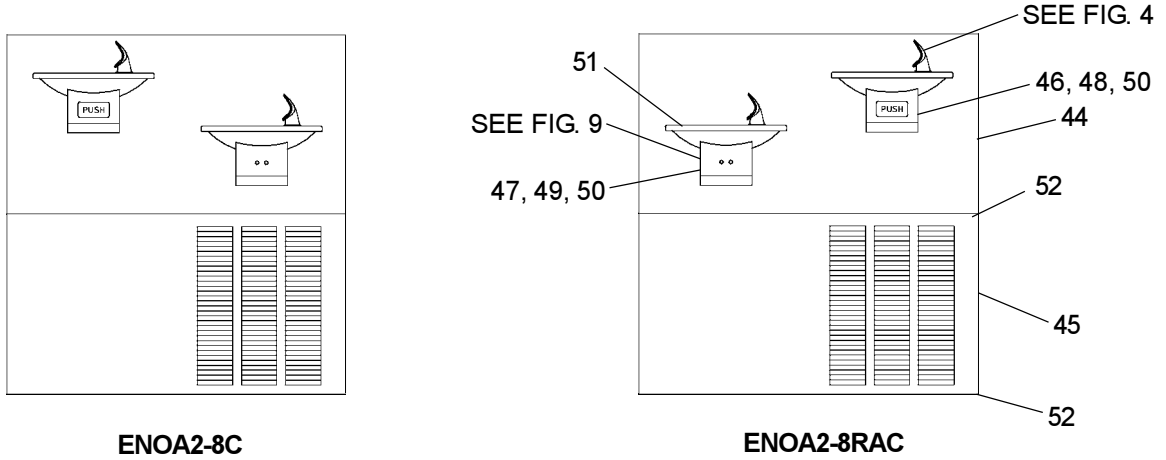

Installer

To assure you install this model easily and correctly, PLEASE READ THESE SIMPLE INSTRUCTIONS BEFORE STARTING THE INSTALLATION. CHECK YOUR INSTALLATION FOR COMPLIANCE WITH PLUMBING, ELECTRICAL AND OTHER APPLICABLE CODES. After installation, leave these instructions inside the fountain for future reference.

IMPORTANT

ALL SERVICE TO BE PERFORMED BY AN AUTHORIZED SERVICE PERSON

IMPORTANT! INSTALLER PLEASE NOTE.

THE GROUNDING OF ELECTRICAL EQUIPMENT SUCH AS TELEPHONE, COMPUTERS, ETC. TO WATER LINES IS A COMMON PROCEDURE. THIS GROUNDING MAY BE IN THE BUILDING OR MAY OCCUR AWAY FROM THE BUILDING. THIS GROUNDING CAN CAUSE ELECTRICAL FEEDBACK INTO A FOUNTAIN, CREATING AN ELECTROLYSIS WHICH CAUSES A METALLIC TASTE OR AN INCREASE IN THE METAL CONTENT OF THE WATER. THIS CONDITION IS AVOIDABLE BY USING THE PROPER MATERIALS AS INDICATED. ANY DRAIN FITTINGS PROVIDED BY THE INSTALLER SHOULD BE MADE OF PLASTIC TO ELECTRICALLY ISOLATE THE FOUNTAIN FROM THE BUILDING PLUMBING SYSTEM.

<p>FIG. 1</p>	<p style="text-align: center;">OPERATION OF QUICK CONNECT FITTINGS</p> <p>FIG. 2</p>
<p>FIG. 3</p>	<p>FIG. 4</p>

ENOA2-8RAC

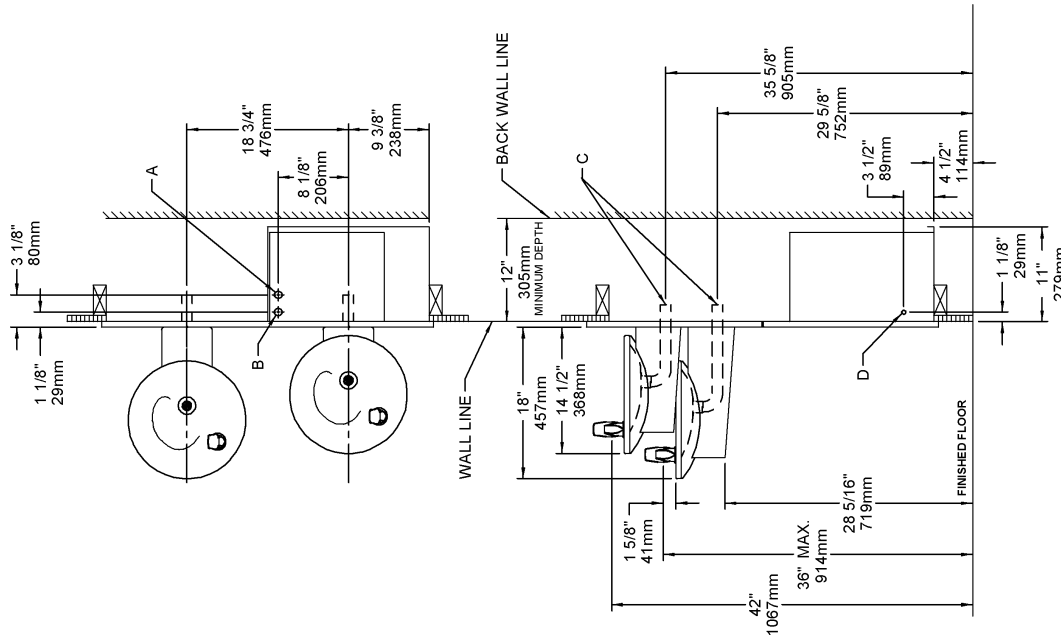

ENOA2-8C

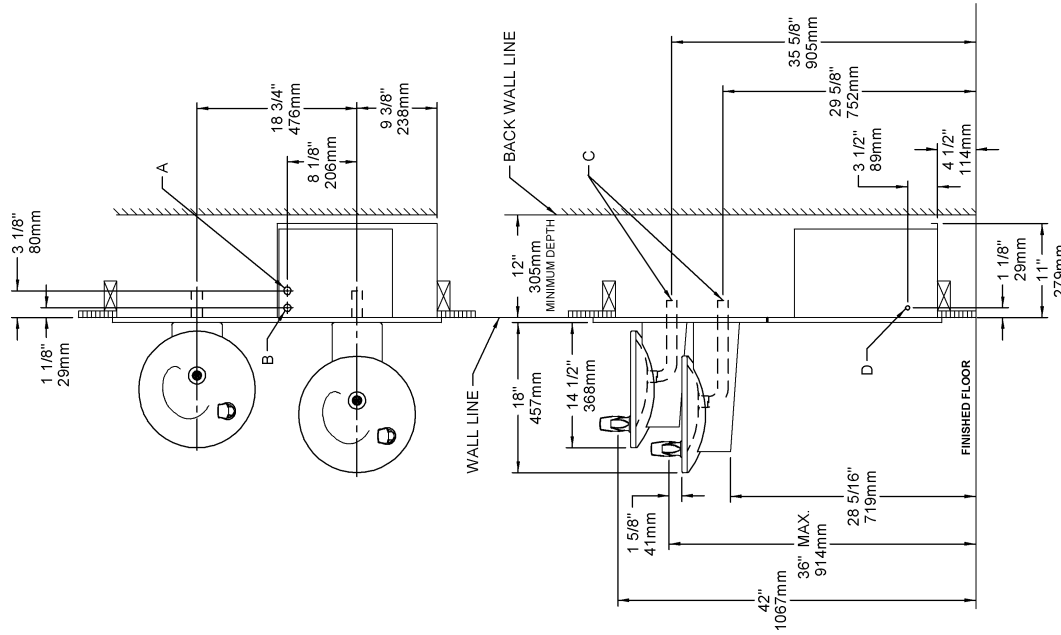

FIG. 5

LEGEND
 A = 3/8" O.D. TUBE CONNECT (CHILLER WATER OUTLET)
 B = 3/8" O.D. TUBE CONNECT (CHILLER WATER INLET) SHUT OFF VALVE BY OTHERS
 C = 1-1/4" TRAP NOT FURNISHED
 D = ELECTRICAL INLET

INSTALLATION INSTRUCTIONS

1. **Install** remote chiller. Remove front panel of chiller. Remove and discard cardboard inner pack from between compressor and side panel. Slide chiller onto the shelf and position it to the left side of shelf. (See Figure 5)
NOTE: Building construction must allow for adequate air flow on both sides, top, and back of chiller. See chiller instructions for additional instructions.
2. **Make** water supply connections. Install a shut-off valve and union connection to building water supply (valve and union not provided). Turn on the water supply and flush the line thoroughly.
3. **ENOA MODELS:** Make connection between remote chiller and building supply line. Inlet port is marked on the chiller (1/4" O.D. copper tube). Bend the copper tube (provided) at an appropriate length from chiller to opening in frame. Install a 1/4" x 3/8" union (provided) on the marked chiller inlet port. Connect building supply line to union. (See Figure 8)
4. **Hang** the upper panel on the mounting frame hanger. Align holes in the panel with the holes in the mounting frame. Be sure that panel is engaged with hanger at top of frame before releasing it.
5. **Install** the fountain. Remove access cover plate on underside of fountains and save the screws. Mount the fountain to the upper panel and the wall frame with (4) 5/16" x 3/4" (19mm) long bolts and nuts (provided). Tighten securely.
6. **Attach** waste tube (1 1/4" OD) to 1 1/4" OD slip trap (provided by others).
7. **ENOA MODELS:** Make connections between remote chiller outlet tube and fountain strainer. Outlet port is marked on the chiller (3/8" O.D. copper tube). Install a 3/8" x 3/8" union (provided) on the marked chiller outlet port. Insert the 3/8" unplated copper water line (provided) into the union and the inlet side of the strainer by pushing it in until it reaches a positive stop, approximately 3/4" (19mm). Connect 1/4" copper tubing coming from fountain to the strainer. Turn on water supply and check for leaks. **DO NOT SOLDER TUBES INSERTED INTO THE STRAINER AS DAMAGE TO THE O-RINGS MAY RESULT.** (See Figure 8).
8. **These** products are designed to operate on 20-105 PSIG supply line pressure. If inlet pressure is above 105 PSIG, a pressure regulator must be installed in the supply line. Any damage caused by reason of connecting these products to supply line pressures lower than 20 PSIG or higher than 105 PSIG is not covered by warranty.
9. **Make** electrical connections to the chiller. See chiller instructions.
10. **Check** stream height from bubbler. Stream height is factory set at 35 PSI. If supply pressure varies greatly from this, remove items 3 & 4 and adjust the screw on regulator (Item 12). Clockwise adjustment will raise stream height and counter-clockwise will lower stream height. For best adjustment stream should hit basin approximately 6 1/2" from the bubbler.
11. **Mount** lower panel. Loosen the (2) #10-24 x 5/8" (16mm) screws at frame bottom lip. Slide upper tongue of lower panel under lower edge of already installed upper panel. Tighten previously loosened screws securely.
12. **Replace** bottom access panel to fountain basin using screws provided. Tighten securely.

TROUBLE SHOOTING AND MAINTENANCE

1. **Orifice Assy:** Minerals deposits on orifice can cause water flow to spurt or not regulate. Mineral deposits may be removed from the orifice with a small round file not over 1/8" diameter or a small diameter wire. **CAUTION:** Do not file or cut orifice materials.
2. **Stream Regulator:** If orifice is free of material deposits regulate water flow according to instruction 10 stated above.
3. **Sensor Control:** The sensor has a 2 second delay time. If sensor fails to operate valve mechanism or operates erratically, check the following:
 - a) Ensure there are no obstructions within a 40 inch radius from the front of fountain.
 - b) Check wire connections at the solenoid valve and at the sensor. **CAUTION:** Make sure unit is unplugged before checking any wiring.
 - c) Ensure proper operation of solenoid valve. If there is an audible clicking sound yet no water flows, look for an obstruction in the valve itself or elsewhere in the water supply line. **WARNING:** Do not expose sensor to direct sunlight.
4. **Sensor Range Adjustment:** The electronic sensor used in this fountain is factory pre-set for a "visual" range of 36 inches. If actual range varies greatly from this, or a different setting is desired, follow the range adjustment procedure below:
 - a) Remove bottom cover of fountain.
 - b) Remove sensor by removing washers and nuts that secure sensor on studs.
 - c) Locate range adjustment screw between the red lenses of the sensor, then with a small tip screwdriver, rotate the range adjusting screw clockwise to increase range or counter-clockwise to decrease range. 1/4 turn of screw is equal to approximately 12 - 18 inches of range. **CAUTION:** Complete range of sensor (24 - 48 inches) is only one turn of the adjusting screw.
 - d) Remount sensor on studs and replace bottom cover.

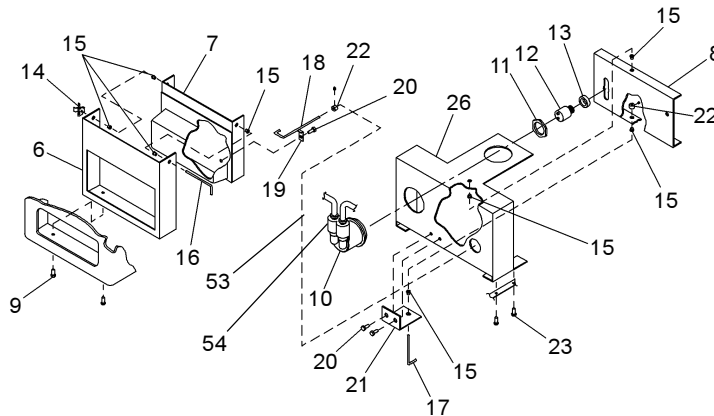

FIG. 6

ENOA2-8C ENOA2-8RAC

PARTS LIST		
ITEM NO.	PART NO.	DESCRIPTION
1	51349C	Bubbler Assembly
2	40322C	Orifice Assembly
3	50934C	Housing Assembly
4	50168C	Pedestal
5	75580C	Bubbler Locknut
6	21804C	Push Bar Mounting Bracket
7	21810C	Push Bar Assembly
8	21806C	Regulator Activator Arm
9	70426C	Screw - #8-32 X .25 THMS
10	50986C	Holder-Regulator
11	40045C	Hex Nut
12	61313C	Regulator
13	56082C	Regulator Nut
14	75555C	Clip
15	50198C	Bushing - Nylon
16	70410C	Rod - Pivot
17	70425C	Rod - Pivot
18	70378C	Rod - Push
19	21705C	Clip - Push Rod
20	70002C	Screw - #10 X .50 HHSM
21	21844C	Pivot Rod Bracket
22	40206000	Retainer
23	112627543890	Screw - #10-24 X .37 PHTC
24	45336C	Strainer & Ferrule Assembly
25	50074C	Gasket - Tailpipe
26	50377C	Gasket - Tailpipe
27	22525C	Regulator Mounting Bracket
28	50203C	Strain Relief
29	45330C	Waste Arm
30	70852C	Tee - 3/8
31	70745C	Union - 3/8 X 1/4
32	55996C	Strainer
33	31376C	Power Cord
34	75507C	Fitting - 1/4 NPTF X 1/4 O.D.
35	31272C	Solenoid Valve Assembly
36	38417001	Screw - #8-18 X .37 HHSM
37	22526C	Solenoid Mounting Bracket
38	70256C	Screw - 1/4-20 X .38 HHTC
39	70817C	Elbow - 1/4 X 1/4
40	70016C	Hex Nut - #10-32
41	34783003	Washer - Star #10
42	31384C	Sensor Assembly
43	51409C	Spacer - 1/2 X .44
44	28185C	Back Panel RH ADA
	28187C	Back Panel LH ADA
45	27026C	Lower Panel
46	21822C	Ftn Body & Shell-Short
47	22535C	Ftn Body & Shell-Long
48	21845C	Cover Plate-Short
49	21846C	Cover Plate-Long
50	70055C	Speed Nut
51	55001026	Basin-Swirlflow
52	111008343890	Screw - #10-24 X .62 HHMS
53	56092C	Poly Tube 48" (Cut To Length)
54	62086C	Tube - Water In
55	62117C	Tube - CU 1/4 X 12.00
NS	70199C	Bolt - 5/16-18 X 1.75 Lg.
NS	70020C	Nut - Hex 5/16-18
NS	74080053	Spacer

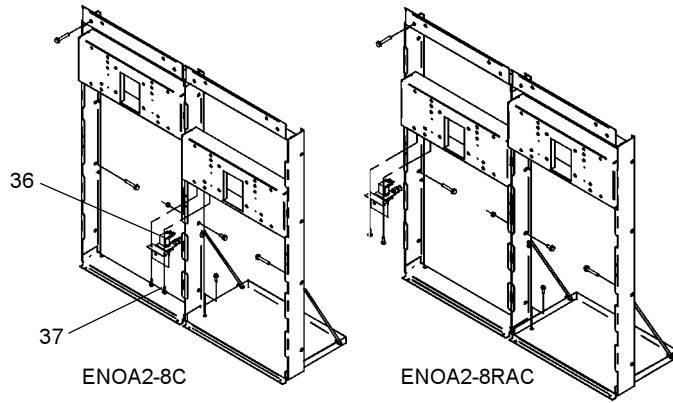

FIG. 7

ENOA2-8C/ENOA2-8RAC TUBE ROUTING

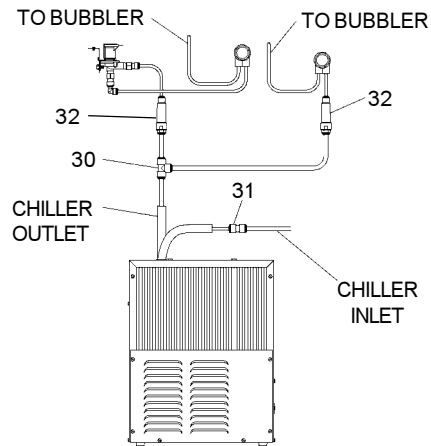

FIG. 8

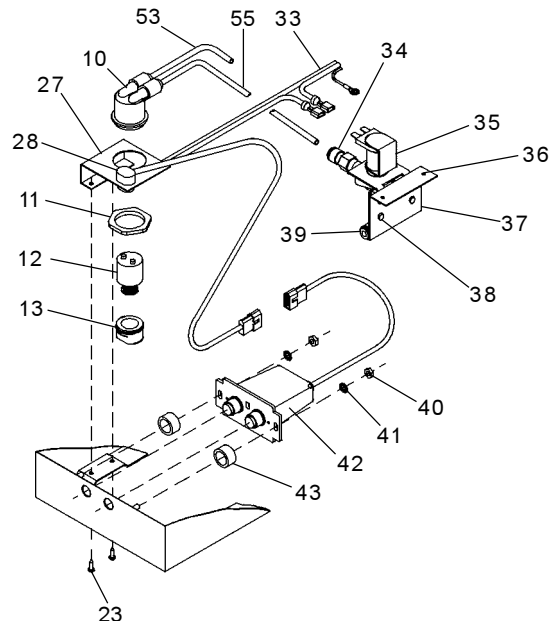

FIG. 9

FOR PARTS, CONTACT YOUR LOCAL DISTRIBUTOR OR CALL 1.800.323.0620
 ELKAY MANUFACTURING COMPANY • 2222 CAMDEN COURT • OAK BROOK, IL 60523 • 630.574.8484