

Installation/Care/Use Manual

Soft Sides® Refrigerated Fountains with FLEXI-GUARD®

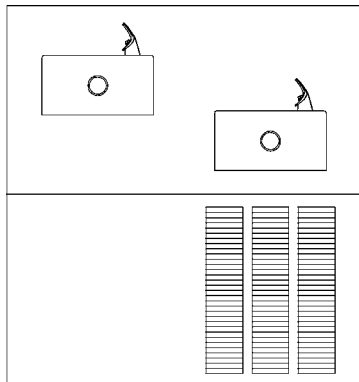

ERFP28C, LNTE8C

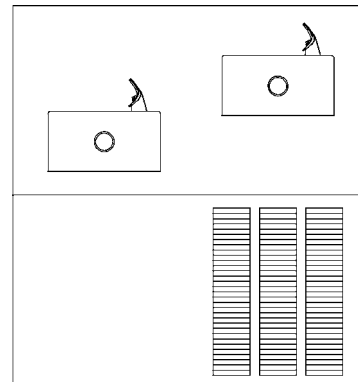

ERFP28RAC, LNTE8RAC

Installer

To assure you install this model easily and correctly, PLEASE READ THESE SIMPLE INSTRUCTIONS BEFORE STARTING THE INSTALLATION. CHECK YOUR INSTALLATION FOR COMPLIANCE WITH PLUMBING, ELECTRICAL AND OTHER APPLICABLE CODES. After installation, leave these instructions inside the fountain for future reference.

IMPORTANT

ALL SERVICE TO BE PERFORMED BY AN AUTHORIZED SERVICE PERSON

IMPORTANT! INSTALLER PLEASE NOTE.

THE GROUNDING OF ELECTRICAL EQUIPMENT SUCH AS TELEPHONE, COMPUTERS, ETC. TO WATER LINES IS A COMMON PROCEDURE. THIS GROUNDING MAY BE IN THE BUILDING OR MAY OCCUR AWAY FROM THE BUILDING. THIS GROUNDING CAN CAUSE ELECTRICAL FEEDBACK INTO A FOUNTAIN, CREATING AN ELECTROLYSIS WHICH CAUSES A METALLIC TASTE OR AN INCREASE IN THE METAL CONTENT OF THE WATER. THIS CONDITION IS AVOIDABLE BY USING THE PROPER MATERIALS AS INDICATED. ANY DRAIN FITTINGS PROVIDED BY THE INSTALLER SHOULD BE MADE OF PLASTIC TO ELECTRICALLY ISOLATE THE FOUNTAIN FROM THE BUILDING PLUMBING SYSTEM.

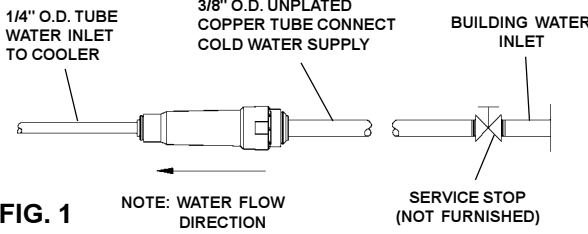
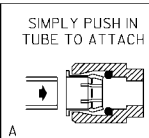
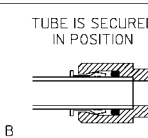
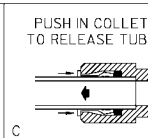
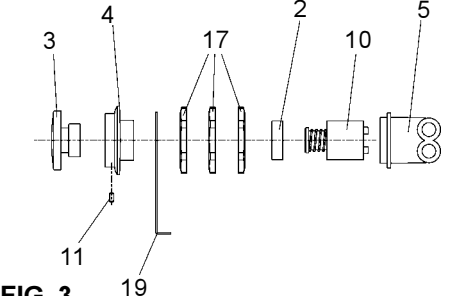
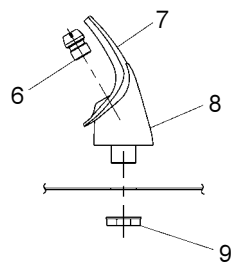
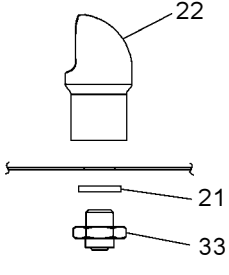
 <p>FIG. 1</p>	<p style="text-align: center;">OPERATION OF QUICK CONNECT FITTINGS</p> <div style="display: flex; justify-content: space-around;"> <div style="text-align: center;"> <p>A</p>  <p>SIMPLY PUSH IN TUBE TO ATTACH</p> </div> <div style="text-align: center;"> <p>B</p>  <p>TUBE IS SECURED IN POSITION</p> </div> <div style="text-align: center;"> <p>C</p>  <p>PUSH IN COLLET TO RELEASE TUBE</p> </div> </div> <p style="text-align: center;">PUSHING TUBE IN BEFORE PULLING IT OUT HELPS TO RELEASE TUBE</p> <p>FIG. 2</p>
 <p>FIG. 3</p>	 <p>FIG. 4</p> <p>NOTE: WHEN INSTALLING REPLACEMENT BUBBLER AND PEDESTAL, TIGHTEN NUT (ITEM 9 OR 33) ONLY TO HOLD PARTS SNUG IN POSITION. DO NOT OVER TIGHTEN.</p>
 <p>FIG. 5</p>	

LNTE8RAC

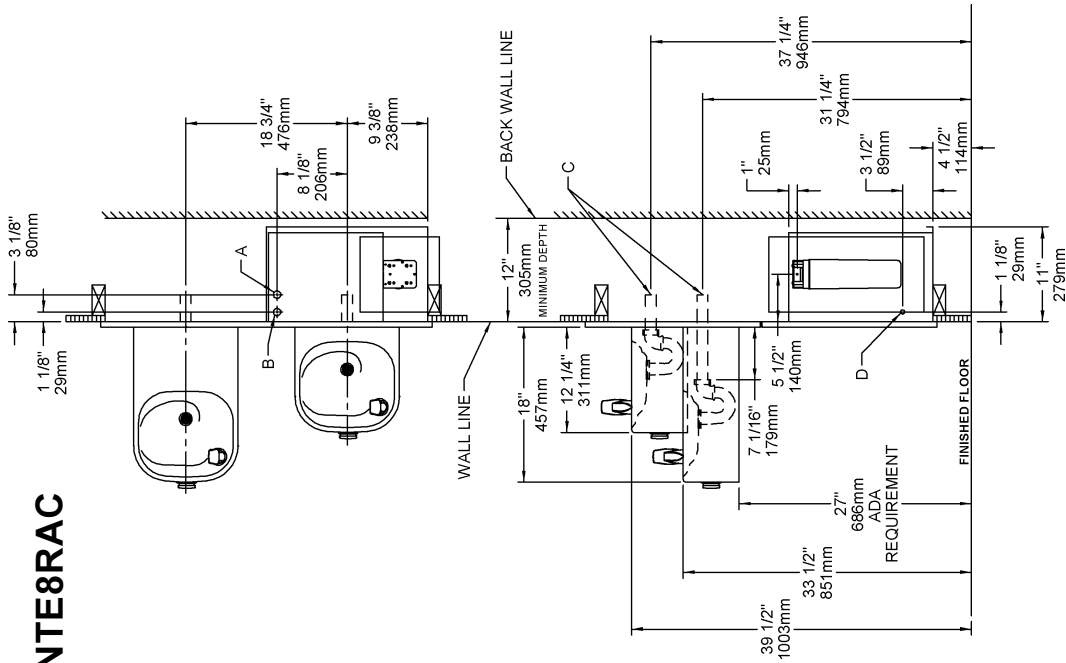

LNTE8C

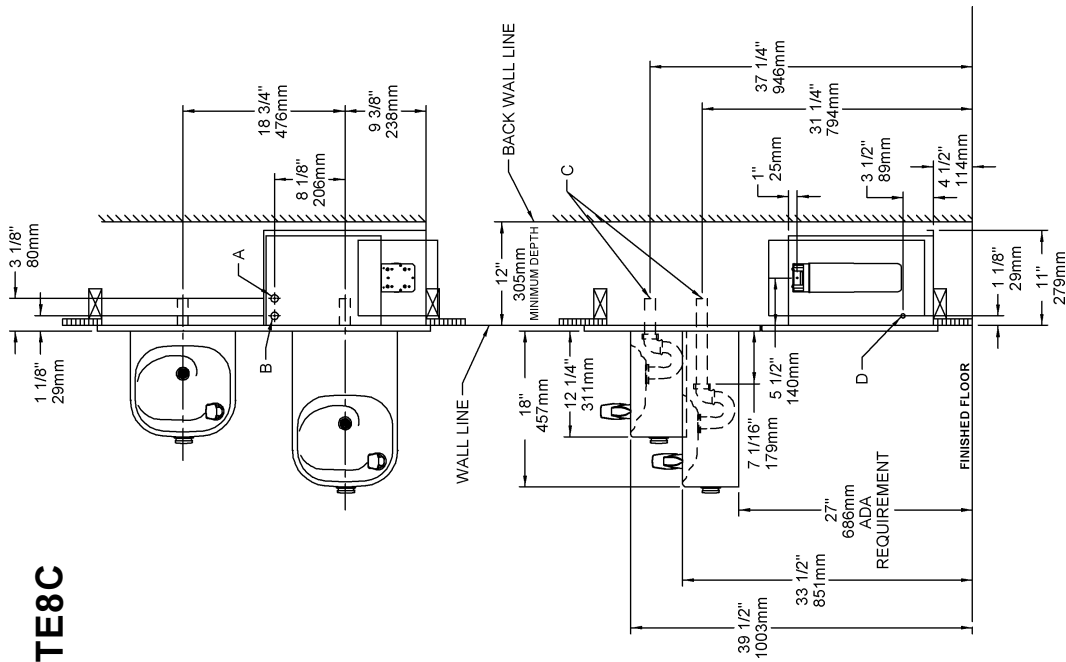

FIG. 6

LEGEND
 A = 1/4" O.D. TUBE CONNECT (CHILLER WATER OUTLET)
 B = 3/8" O.D. TUBE CONNECT (CHILLER WATER INLET) SHUT OFF VALVE BY OTHERS
 C = 1-1/4" TRAP FURNISHED
 D = ELECTRICAL INLET

INSTALLATION INSTRUCTIONS

- 1. Install remote chiller.** Remove front panel of chiller. Remove and discard cardboard inner pack from between compressor and side panel. Slide chiller onto the shelf and position it to the left within the guides on the shelf.
NOTE: Building construction must allow for adequate air flow on both sides, top, and back of chiller. See chiller instructions for additional instructions.
- 2. Make water supply connections.** Install a shut-off valve and union connection to building water supply (valve and union not provided). Turn on the water supply and flush the line thoroughly.
- 3. ERFP MODELS:** Make connection between remote chiller and building supply line. Inlet port is marked on the chiller (1/4" O.D. copper tube). Bend the copper tube (provided) at an appropriate length from chiller to opening in frame. Install the in-line strainer (provided with chiller) by pushing it in until it reaches a positive stop, approximately 3/4" (19mm) on the marked chiller inlet port. Connect building supply line to strainer. **DO NOT SOLDER TUBES INSERTED INTO THE STRAINER AS DAMAGE TO THE O-RINGS MAY RESULT.** (See Figures 7 or 13).
LNTE MODEL: Mount filter head assembly to side of chiller (See Figure 9). Make connection between filter and building supply line (3/8" O.D. tube not provided). Inlet port is marked on the chiller (1/4" O.D. copper tube). Install a 1/4" x 1/4" union (provided) on the inlet port. Insert the 1/4" poly tubing (provided) into fitting on filter and connect to the union on the chiller. **DO NOT SOLDER TUBES INSERTED INTO THE UNIONS AS DAMAGE TO THE O-RINGS MAY RESULT.** (See Figures 8 or 12).
- 4. Hang** the upper panel on the mounting frame hanger. Align holes in the panel with the holes in the mounting frame. Be sure that panel is engaged with hanger at top of frame before releasing it.
- 5. Install** the fountains. Remove access cover plates on underside of fountains and save the screws. Mount the fountains to the upper panel and the wall frame with (4) 5/16" x 3/4" (19mm) long bolts and nuts (provided). Tighten securely.
NOTE: The short fountain should be mounted to the upper left hand side of the panel.
- 6. Remove** elbow from end of p-trap and attach it to drain tube. Re-attach elbow to p-trap and cut waste tube to required length using plumbing hardware and trap as a guide.
- 7. ERFP MODELS:** Make connections between remote chiller outlet tube and fountains. Outlet port is marked on the chiller (1/4" O.D. copper tube). Install a 1/4" tee (provided) on the marked chiller outlet port. Insert the 1/4" poly tubing coming from the fountains into the tee. Turn on water supply and check for leaks. **DO NOT SOLDER TUBES INSERTED INTO THE TEE AS DAMAGE TO THE O-RINGS MAY RESULT.** (See Figures 7 or 13).
LNTE MODEL: Make connections between remote chiller and fountains. Outlet port is marked on the chiller (1/4" O.D. copper tube). Install a 1/4" tee (provided) on the marked chiller outlet port. Insert the 1/4" poly tubing coming from the fountains into the tee. Turn on water supply and check for leaks. **DO NOT SOLDER TUBES INSERTED INTO THE TEE AS DAMAGE TO THE O-RINGS MAY RESULT.** (See Figures 8 or 12).
- 8. These** products are designed to operate on 20-105 PSIG supply line pressure. If inlet pressure is above 105 PSIG, a pressure regulator must be installed in the supply line. Any damage caused by reason of connecting these products to supply line pressures lower than 20 PSIG or higher than 105 PSIG is not covered by warranty.
- 9. Make** electrical connections to the chiller. See chiller instructions.
- 10. Check** stream height from bubbler. Stream height is factory set at 35 PSI. If supply pressure varies greatly from this, remove items 3 & 4 and adjust the screw on regulator (Item 10). Clockwise adjustment will raise stream height and counter-clockwise will lower stream height. For best adjustment stream should hit basin approximately 6 1/2" from the bubbler.
- 11. Mount** lower panel. Loosen the (2) #10-24 x 5/8" (16mm) screws at frame bottom lip. Slide upper tongue of lower panel under lower edge of already installed upper panel. Tighten previously loosened screws securely.
- 12. Replace** bottom access panel to fountain basin using screws provided. Tighten securely.

TROUBLE SHOOTING AND MAINTENANCE

- 1. Orifice Assy:** Mineral deposits on orifice can cause water flow to spurt or not regulate. Mineral deposits may be removed from orifice with a small round file not over 1/8" diameter or a small diameter wire. **CAUTION:** Do not file or cut orifice materials.
- 2. Stream Regulator:** If orifice is free of material deposits, regulate flow according to instruction 10 stated above.
- 3. Actuation of Quick Connect Water Fittings:** Cooler is provided with lead-free connectors which utilize an o-ring water seal. To remove tubing from the fitting, relieve water pressure, push in on the gray collar while pulling on the tubing (See Figure 2). To insert tubing, push tube straight into the fitting until it reaches a positive stop, approximately 3/4".

ERFP28C/ERFP28RAC TUBE ROUTING

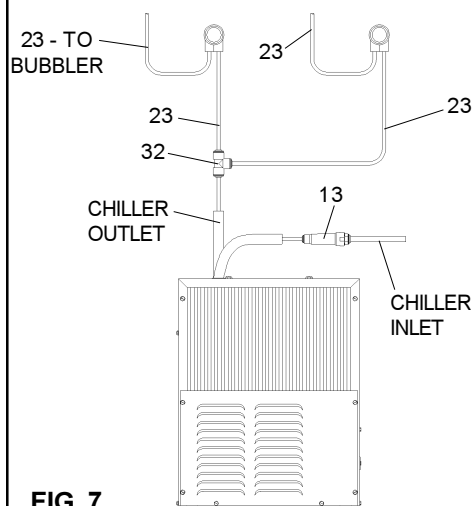

LNTE8C/LNTE8RAC TUBE ROUTING

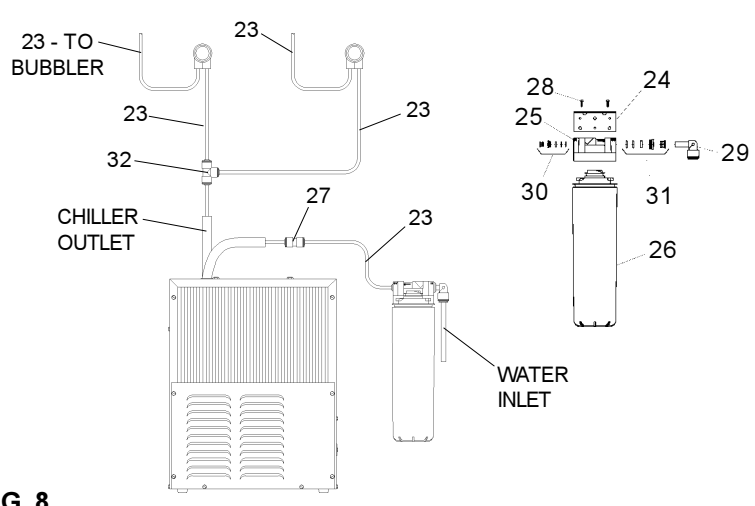

PARTS LIST		
ITEM NO.	PART NO.	DESCRIPTION
1	LK464	Drain
2	15005C	Retaining Nut
3	45662C	Push Button
4	45663C	Push Button Sleeve
5	50986C	Regulator Holder
6	A54874	Orifice Assy
7	56011C	Housing Assy
8	55997C	Pedestal
9	75580C	Bubbler Locknut
10	61313C	Regulator
11	70022C	Setscrew - #6-32 X .31"
12	110711942550	Screw - #8-32 X .38" TH
13	55996C	Strainer
14	55000604	Fountain Arm - Short
	55000612	Fountain Arm - Long
	27959C	Fountain Arm - Long (Glassfiller)
15	55000661	Bottom Cover Plate - Short
	55000665	Bottom Cover Plate - Long
16	26839C	Back Panel - ERFP28C
17	40045C	Hex Nut
18	70055C	Speed Nut
19	27057C	Regulator Mounting Bracket
20	27026C	Lower Panel
21	100322740560	Gasket - VR Model
22	45392C	Bubbler - VR Model
23	56092C	Poly Tubing (Cut To Length)
24	22490C	Filter Mounting Bracket
25	51294C	Filter Head Assy
26	51299C	Filter Assy
27	70683C	Union - 1/4
28	70792C	Screw - #8-18 x .75" PH
29	70818C	Elbow - 3/8" (10mm)
30	70822C	Fitting - Superseal 1/4" (6mm)
31	70823C	Fitting - Superseal 3/8" (10mm)
32	70862C	Tee - 1/4
33	15009C	Nipple Assy
NS	111577243890	Screw - Mach 5/16-18 x 3/4
NS	111577343890	Nut - Hex 5/16-18

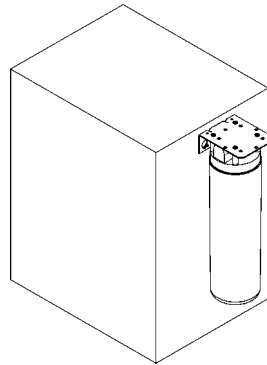

FIG. 9

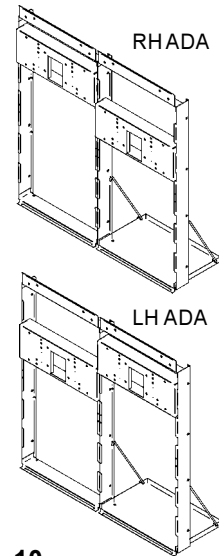

FIG. 10

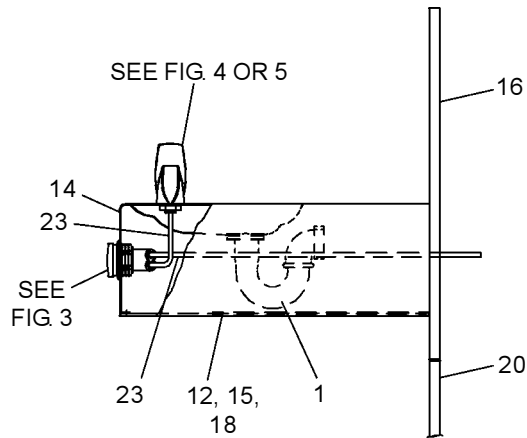

FIG. 11

LNTE8C W/GLASSFILLER

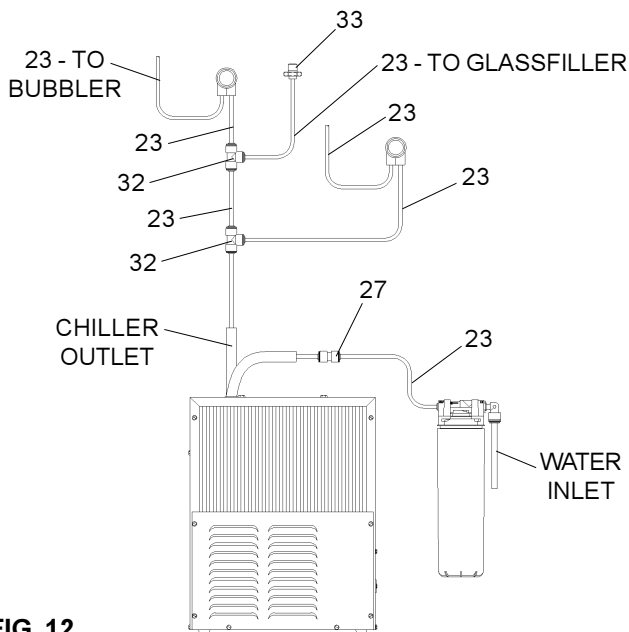

FIG. 12

ERFP28C/ERFP28RAC W/GLASSFILLER

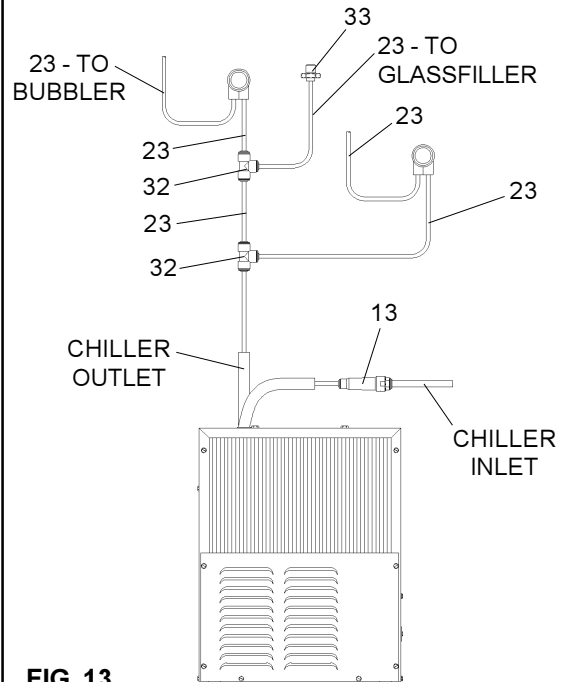

FIG. 13

FOR PARTS, CONTACT YOUR LOCAL DISTRIBUTOR OR CALL 1.800.323.0620
 ELKAY MANUFACTURING COMPANY • 2222 CAMDEN COURT • OAK BROOK, IL 60523 • 630.574.8484