

**OLD STYLE HOT WATER TANK  
USED ON MODEL S-300-CB**

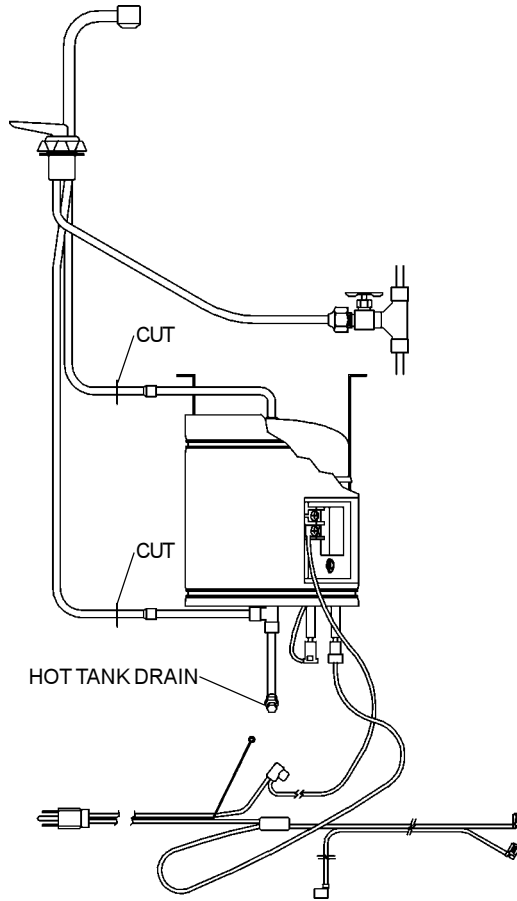

**OLD STYLE HOT WATER TANK  
USED ON MODELS SCWT-CB AND WM-CB**

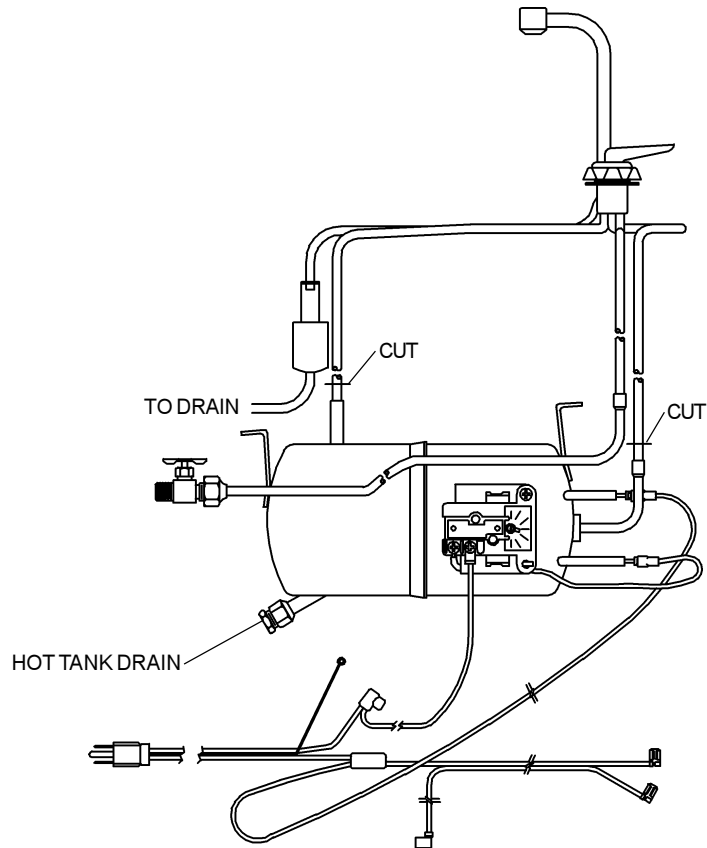

# NEW STAINLESS STEEL HOT WATER TANK KIT

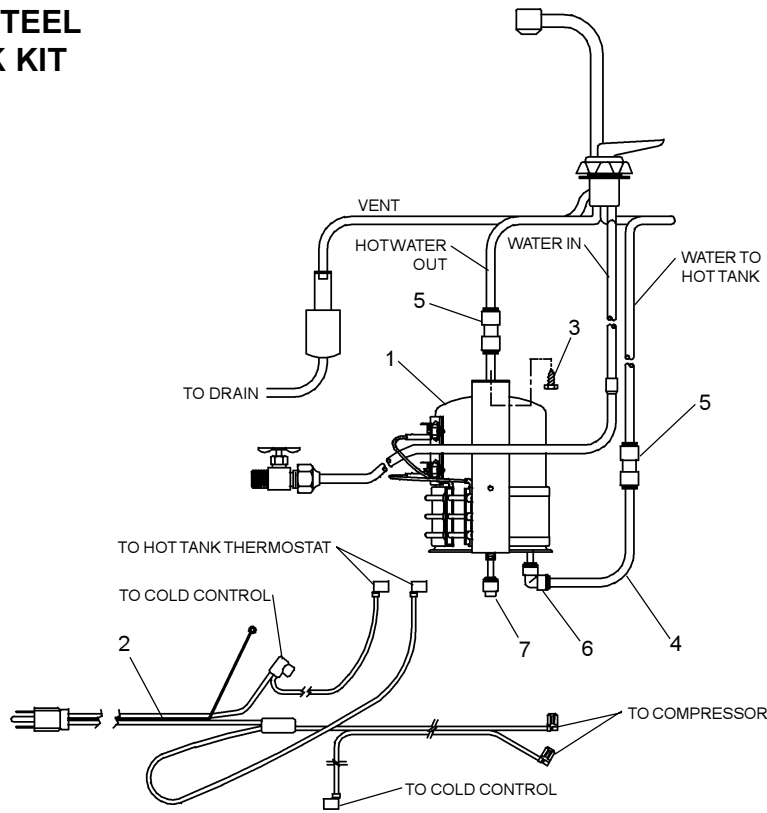

## HALSEY TAYLOR HOT TANK REPLACEMENT INSTRUCTIONS

1. Disconnect electrical power to the water cooler and shut off water to the unit.
2. Remove the necessary panel(s) to gain access to the hot tank.
3. Drain the hot tank by removing the drain plug from the bottom of the tank.
4. Refer to the drawing of the old style hot tank for the model to be serviced. Cut the water tubes that are connected to the hot tank in the locations shown.
5. Remove and discard the power cord from the unit by disconnecting from the compressor, cold control, and the hot tank.
6. Remove the hot tank.
7. Using the template for the model being serviced, locate and drill the specified holes in the shelf.
8. Using the two furnished screws (Item 3), mount the new hot tank under the shelf.
9. Route the hot valve tubes to the hot tank and connect using the gray quick connect water fittings. To insert tubing push tube straight into fitting until it reaches a positive stop, approximately 3/4". To remove tubing from the fitting, relieve water pressure and push in on gray collar while pulling on the tubing.
10. Using the supplied power cord, re-wire the unit as shown in the drawing above. Jumper wire (Item 9) routed from switch to hot tank thermostat. Cut terminals off the fan motor and replace with supplied terminals (Item 10). Route fan motor leads to compressor and attach ribbed lead to the relay and the smooth lead to the overload. Connect power cord leads to the fan motor terminals (ribbed to ribbed, smooth to smooth).
11. Turn on the water supply and fill the hot tank with water by depressing the hot valve. **CHECK FOR LEAKS.**
12. Plug the unit in, making sure the compressor and fan run and the hot tank produces hot water.
13. Replace panels.

NOT SHOWN

ITEM NO.	QTY.	DESCRIPTION	SCWT-CB PART NO.	WM-CB PART NO.	S-300-CB PART NO.
1	1	HOT TANK ASSY	36129C	36129C	36129C
2	1	POWERCORD	36136C	36137C	36135C
3	2	SCREW #10 X .50 HHSM	70002C	70002C	70002C
4	1	TUBE - CU 1/4 X 12.00"	62177C	62177C	62177C
5	2	UNION - 1/4	70683C	70683C	70683C
6	1	ELBOW - 1/4	70793C	70793C	70793C
7	1	PLUG - DRAIN	70606C	70606C	70606C
8	1	TEMPLATE - HOT TANK MGT.	92537C	92537C	92537C

**Halsey Taylor**®

2222 CAMDEN COURT  
OAKBROOK, IL 60523  
630.574.3500

PRINTED IN U.S.A.

FOR PARTS, CONTACT YOUR LOCAL DISTRIBUTOR OR CALL 1.800.323.0620