

CABLE SHEATH ADJUSTMENT

To Increase Free Play

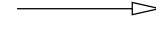

To Reduce Free Play

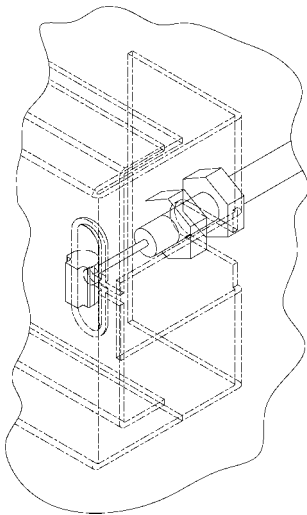

FIG. 2

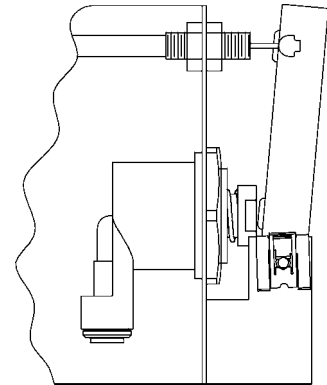

FIG. 3

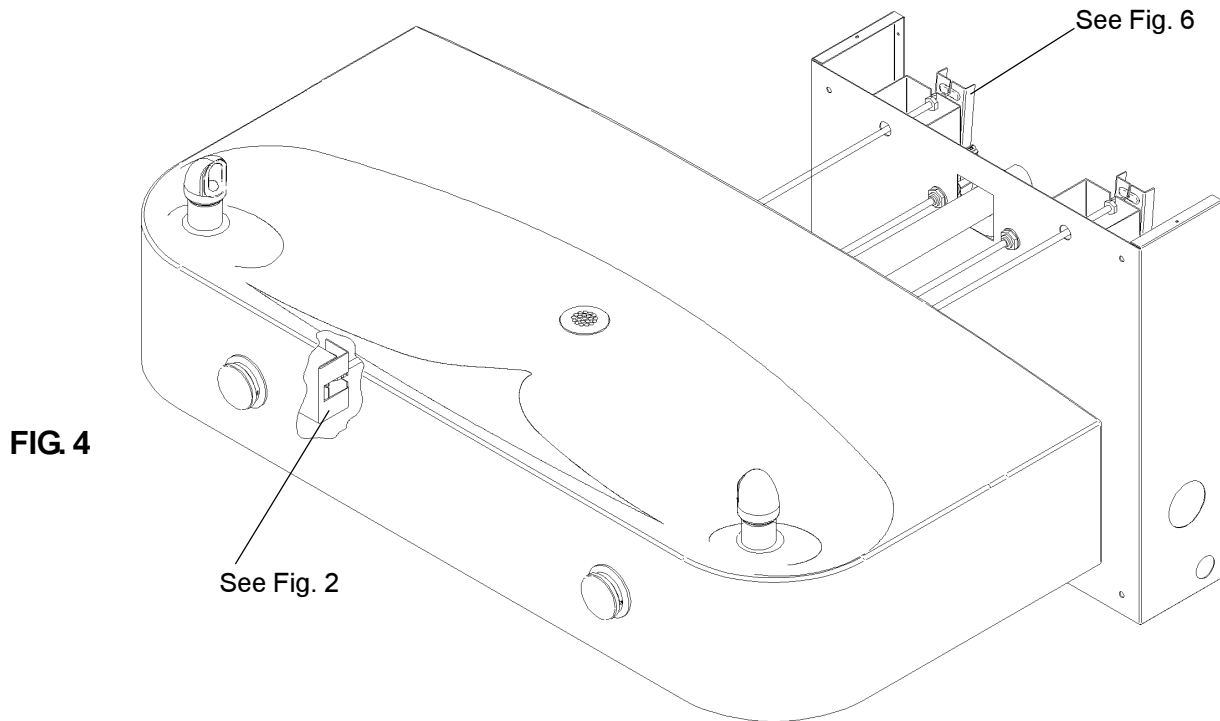

FIG. 4

See Fig. 2

See Fig. 6

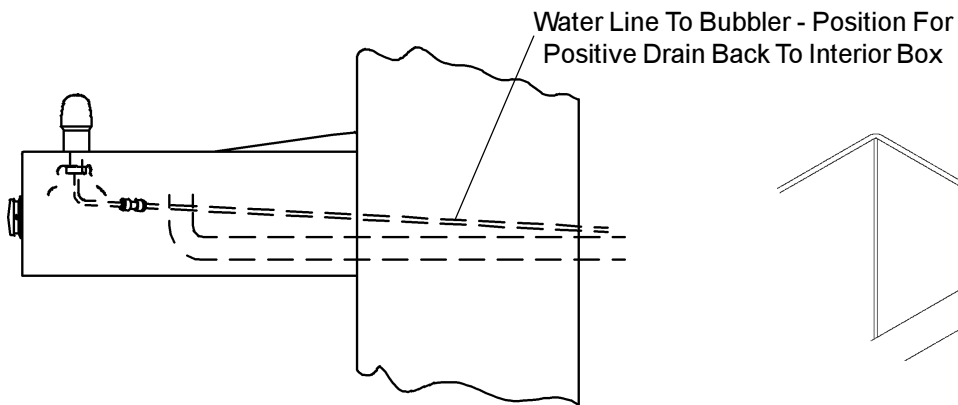

FIG. 5

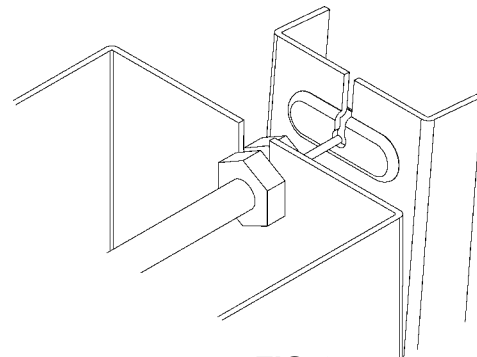

FIG. 6

INSTALLATION INSTRUCTIONS

The freeze resistant package must be mounted on an interior wall in a heated area. The room temperature of the interior heated area must be 50° F (10° C) or higher. The freeze resistant package may be surface or recessed mounted. If recess mounted the surface of the cover must be flush with the interior wall surface. The package is furnished with screws for mounting the cover to the box. If the box is recess mounted, do not fasten the top and bottom of the cover to the box. Use the holes on the front only.

1. Assemble the operating cable to the fountain bracket. (Fountain should be mounted to exterior wall) Create a loop in the cable and thread the free end of the cable through the wall into the freeze resistant box. The adjustment nuts should be in the middle of threaded area on the operating cable. See Figure 6
2. Connect free end of operating cable to the valve-operating bracket. The end of the cables must be recessed into the indents on the pivot brackets.
3. Remove cable free play by adjusting the jam nuts on the ends of the operating cable. See Figure 3
4. Connect water line from fountain bubbler into freeze resistant box. The connection to the box uses a quick connect water fitting. Position the water line, in the fountain, to drain back into interior mounted box. **NOTE: TRIM WATER SUPPLY TUBING TO APPROPRIATE LENGTH, TO ALLOW FOR POSITIVE WATER FLOW.** Any water left standing, in the exterior line, can freeze. See Figure 5

To insert tubing, push tube straight into fitting until it reaches a positive stop. To remove tubing from the fittings, relieve water pressure, push in on dark gray collar while pulling out on the tubing. See Figure 8

5. Connect drain and water supply lines to the freeze resistant fountain. Refer to Figure 1 for component positions. Inline strainer must be used on the inlet water line.

Start-up

1. Turn on building water supply and check all connections for leaks. Repair as required.
2. Stream height is factory set at 35 PSI. If stream height needs to be changed adjust screw on item 15, behind item 3. (See parts list on page 4). Clockwise adjustment raises stream height, counter clockwise adjustment will lower stream.
3. Adjust operating cable as required. Cable system should have a minimal amount of free play to allow for proper valve operation. If the system is too tight the valve will stay in the on position creating constant water flow. Too much free play will result in non-operation of the valve with the push-buttons.
4. Note: Water from the drain back tube will continue to run while the valve is actuated. (Reference Item 16)
5. After cable system is adjusted properly stuff flexible insulation into any openings between the outside wall and the interior box.
6. Recheck all connections. If all connections are leak free replace cover on the freeze resistant box and fountain.

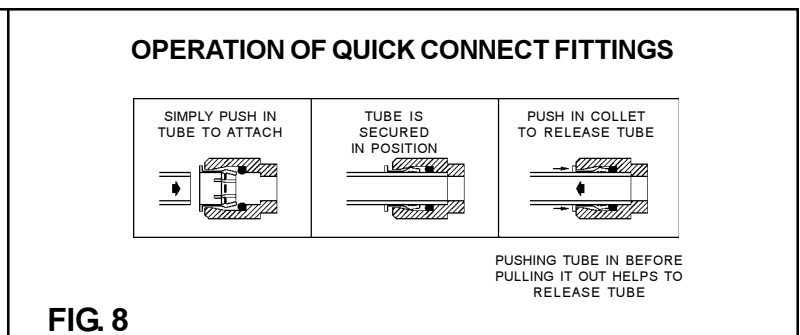
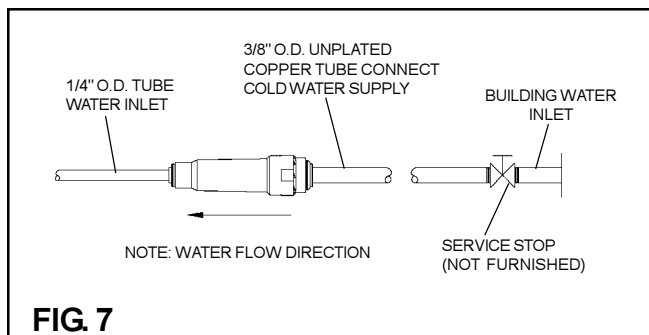

PARTS LIST

ITEM NO.	PARTNO.	DESCRIPTION
1	15005C	NUT - RETAINING
2	28233C	COVER - BODY
3	27948C	BRACKET-REGULATOR PIVOT
4	27951C	BRACKET ASSY
5	28232C	BODY ASSY
6	31525003	O-RING - .375 X .239 X .070
7	40045C	NUT HEX - UNPLTD
8	75555C	CLIP
9	40266C	VALVE - CHECK
10	40267C	INSERT - .25 DIA CU
11	50198C	SNAP BUSHING
12	50986C	HOLDER - REGULATOR
13	56092C	POLY TUBING (CUT TO LENGTH)
14	55996C	STRAINER
15	61313C	REGULATOR - W/RED SPRING
16	66652C	WATER OUTLET ASSY
17	66634C	DRAIN TUBE ASSY
18	70284C	BODY - CHECK VALVE
19	70682C	TEE - 1/4
20	70831C	PIVOT ROD
21	70841C	UNION - BULKHEAD
22	72000835	1-1/4IN SINK TRAP
23	72001843	SLIP ELL 22GA 1 1/4 X 7
24	70793C	ELBOW - 1/4
NS	75582C	OPERATING CABLE
NS	40628C	WASTE TUBE

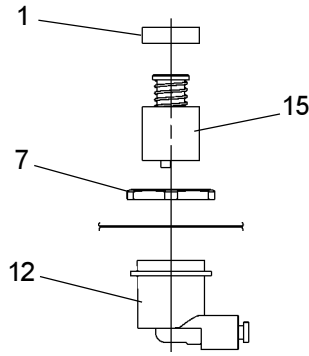

FIG. 9

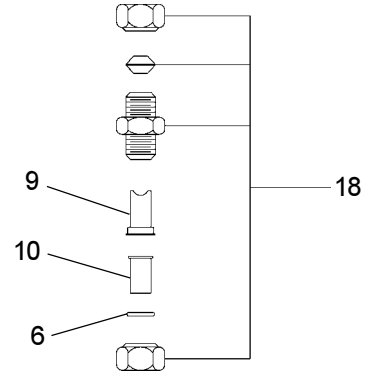

FIG. 10

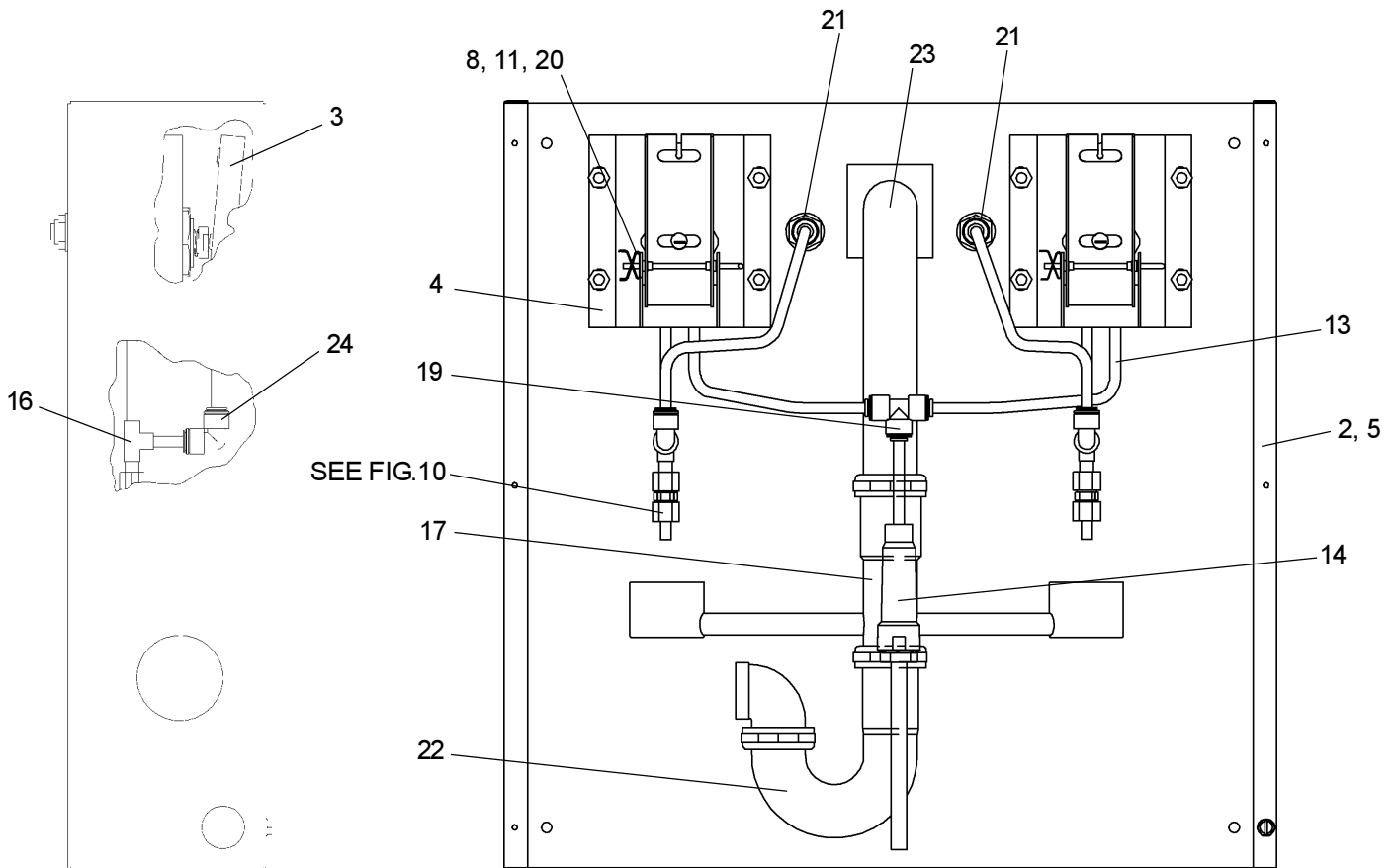

FIG. 11

Halsey Taylor
 2222 CAMDEN COURT
 OAK BROOK, IL 60523
 630.574.3500

FOR PARTS, CONTACT YOUR LOCAL DISTRIBUTOR OR CALL 1.800.323.0620

PRINTED IN U.S.A.