

HTV VANDAL RESISTANT SCREWS & BUBBLER KIT 97933C

KIT CONSISTS OF:

PARTS LIST			
ITEM NO.	QUANTITY	PART NO.	DESCRIPTION
1	1	45392C	VR BUBBLER
2	1	15009C	BUBBLER NIPPLE
3	2	75564C	LOCKWASHER
4	2	75566C	VR SCREW #10 X 1"
5	1	75520C	BIT - PINNED TORX T-25

1. Remove cooler panels to gain access to the bubbler nipple under the basin.
2. Remove the existing bubbler by holding the bubbler nipple and unscrewing the bubbler.
3. If the bubbler nipple is plastic, replace with the new metal bubbler nipple (Item 2) by removing the tube from the quick connect fitting (see Figure A below) and reinserting the tube approximately 3/4" in the metal nipple.
4. Discard the two black rubber bubbler gaskets and reinsert the bubbler nipple through the basin hole.
5. Assemble the two lockwashers (Item 3) to the bubbler nipple (see Figure B).
6. Apply thread sealer (not provided) to the bubbler nipple threads.
7. Assemble the bubbler to the bubbler nipple and tighten the bubbler nipple. The bubbler should be one quarter turn less than desired position when the bubbler fitting is securely tightened from the underside of the basin.
8. For proper function of the lockwashers, the bubbler must be turned the last a quarter turn from the top side of the basin. This assembly method seats the lockwashers properly to prevent easy removal.
9. Operate the cooler to check for water leaks.
10. Reassemble the cooler as required securing the bottom cover with the two vandal resistant screws (Item 4) as shown in Figure C.

OPERATION OF QUICK CONNECT FITTINGS

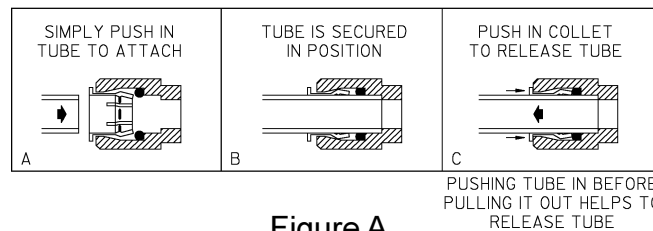

Figure A

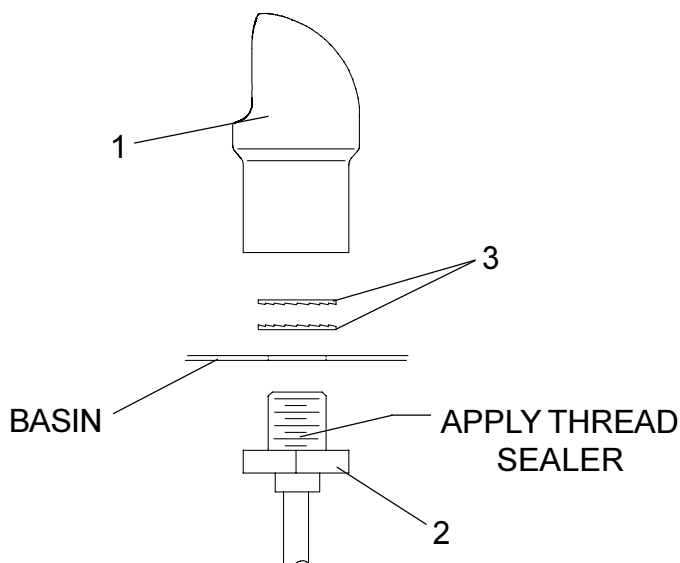

Figure B

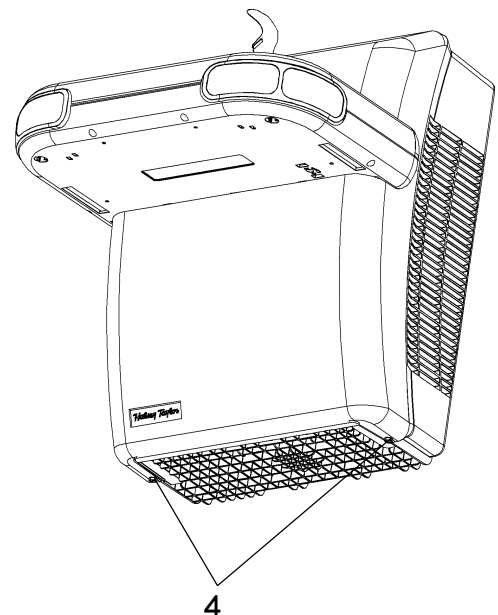

Figure C

FOR PARTS, CONTACT YOUR LOCAL DISTRIBUTOR OR CALL 1.800.323.0620