

Halsey Taylor Owners Manual

Model 4430

Tri-Level Tubular Fountain

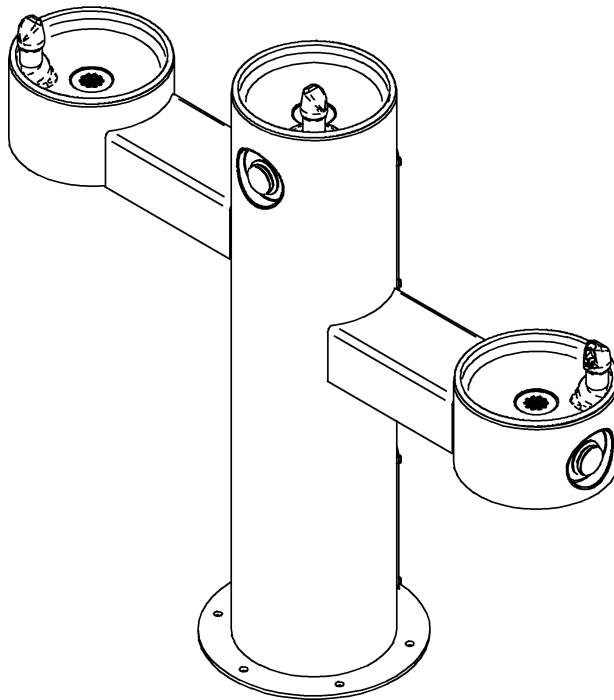

INSTALLER

Halsey Taylor Fountains are among the easiest to install Fountains on the market today. To assure you install these models easily and correctly, PLEASE READ THESE SIMPLE INSTRUCTIONS BEFORE STARTING THE INSTALLATION. CHECK YOUR INSTALLATION FOR COMPLIANCE WITH PLUMBING, ELECTRICAL, AND OTHER APPLICABLE CODES. After installation, leave these instructions with the Fountain for future reference.

IMPORTANT

ALL SERVICE TO BE PERFORMED BY AN AUTHORIZED SERVICE PERSON

IMPORTANT! INSTALLER PLEASE NOTE.

THE GROUNDING OF ELECTRICAL EQUIPMENT SUCH AS TELEPHONE, COMPUTERS, ETC. TO WATER LINES IS A COMMON PROCEDURE. THIS GROUNDING MAY BE IN THE BUILDING OR MAY OCCUR AWAY FROM THE BUILDING. THIS GROUNDING CAN CAUSE ELECTRICAL FEEDBACK INTO A FOUNTAIN, CREATING AN ELECTROLYSIS WHICH CAUSES A METALLIC TASTE OR AN INCREASE IN THE METAL CONTENT OF THE WATER. THIS CONDITION IS AVOIDABLE BY USING THE PROPER MATERIALS AS INDICATED. ANY DRAIN FITTINGS PROVIDED BY THE INSTALLER SHOULD BE MADE OF PLASTIC TO ELECTRICALLY ISOLATE THE FOUNTAIN FROM THE BUILDING PLUMBING SYSTEM.

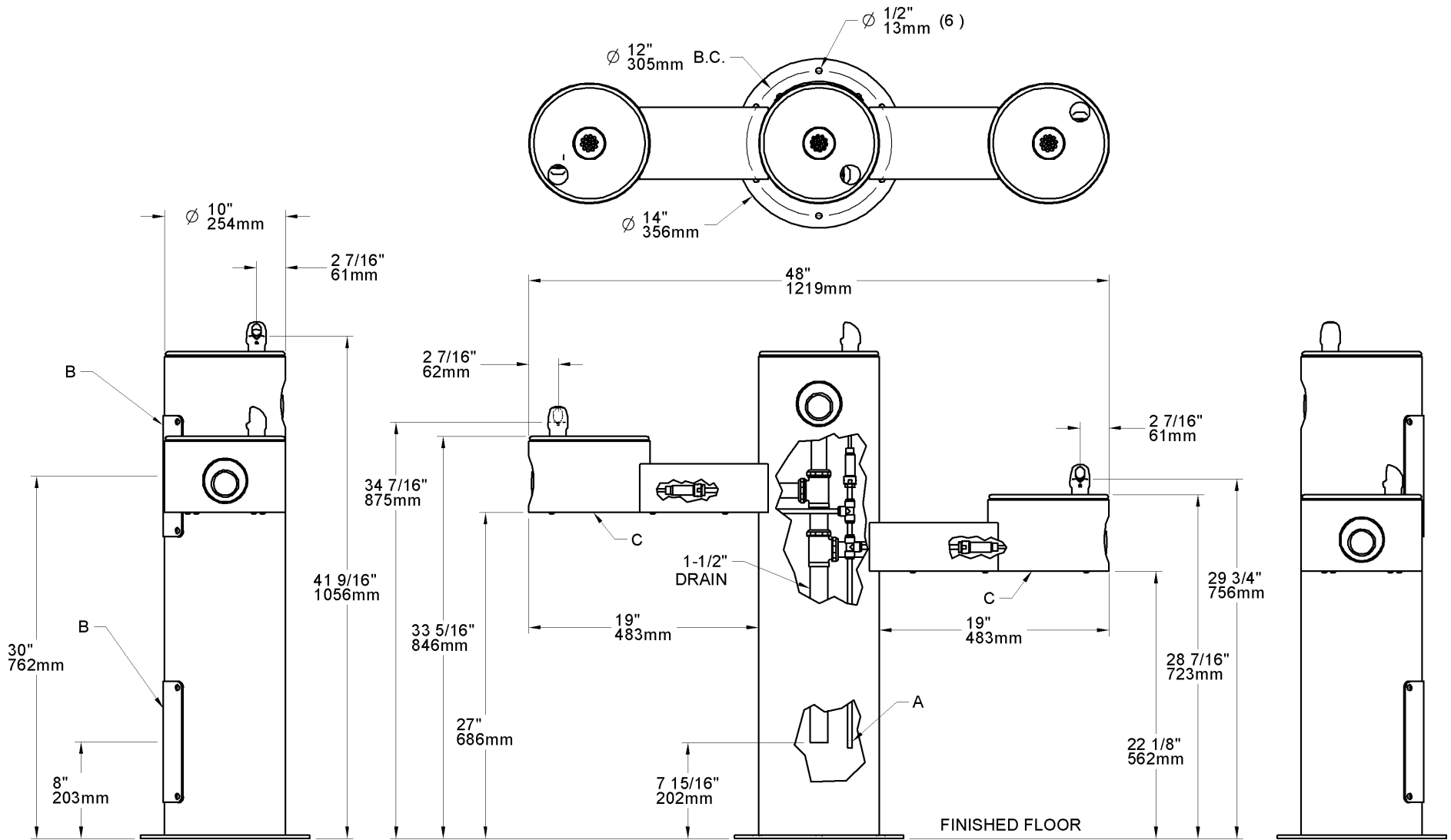

4430 FOUNTAIN

LEGEND

- A = 3/8" O.D. UNPLATED COPPER TUBE CONNECT - SHUT OFF VALVE BY OTHERS
- B = ACCESS PANEL (8" X 10")
- C = REMOVABLE BOTTOM COVER

4430 FOUNTAIN

1. This fountain is to be mounted on a smooth, flat, finished surface with adequate support structure. NOTE: Mounting structure must be capable of supporting 300 lb. load on fountain.
2. Refer to rough-in for plumbing.
3. Install shut-off valve on water supply. (Valve not furnished)
4. Locate and install fountain using 3/8" minimum screws or bolts, (Screws or bolts not furnished).
5. Connect fountain to supply line with a shut-off valve and install a 3/8" unplated copper water line between the valve and the cooler. Remove any burrs from outside of water line. Push the tubes straight into the fittings until they reach a positive stop, approximately 3/4" (See Fig. 2). DO NOT SOLDER TUBES INSERTED INTO THE STRAINER AS DAMAGE TO THE O-RINGS MAY RESULT.
6. Water supply 3/8" O.D. unplated copper tube. Waste 1-1/2" IPS. Contractor to supply waste trap and service stop valve in accordance with local code.
7. Connect water supply and fountain drain. Connect drain waste "Tee" to fountain drain tubes. Connect outlet of "Tee" to drainage system. Water connection and drain must comply with local codes.
8. Turn on water supply and check all connections for leaks. Threaded drain fittings may require thread sealer to create a leak free connection. Apply thread sealer to threaded connection fittings only, not the slip connection fittings.

CAUTION: This fountain is rated for inlet water pressure of 20-105 PSI. A pressure reducing regulator should be used if the inlet water supply exceeds 105 PSI. Any damage caused by reason of connecting this product to supply line pressures lower than 20 psig or higher than 105 psig is not covered by warranty.

9. Connecting lines to be made of unplated copper and should be thoroughly flushed to remove all foreign matter before being connected to fountain. This fountain is manufactured in such a manner that it does not in any way cause taste, odor, color, or sediment problems.

TROUBLE SHOOTING AND MAINTENANCE

Actuation of Quick Connect Water Fittings: Fountain is provided with lead-free connectors which utilize an o-ring water seal. To remove tubing from the fitting, relieve water pressure, push in on the gray collar while pulling on the tubing. (see Fig.2) To insert tubing, push tube straight into fitting until it reaches a positive stop, approximately 3/4".

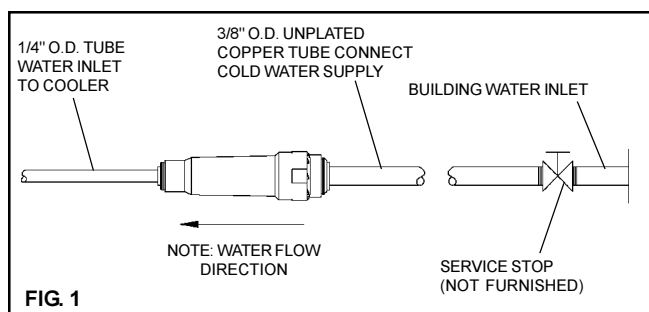
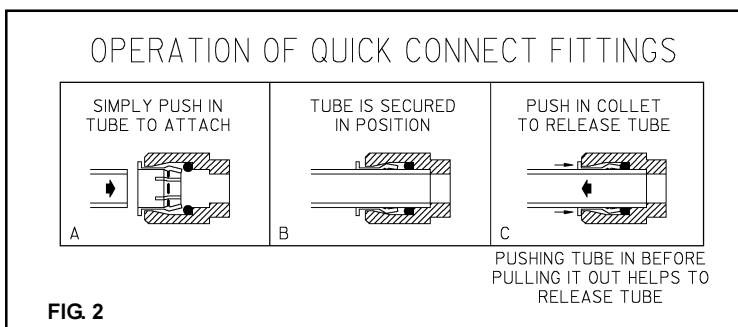

4430 FOUNTAIN

ITEMIZED PARTS LIST

ITEM NO.	PART NO.	DESCRIPTION
1	100147140560	Drain Gasket
2	28308C	Spacer Washer
3	101570540560	Drain Gasket
4	15005C	Regulator Retaining Nut
5	15009C	Nipple Assy. - Bubbler
6	28091C	Nameplate Insert
7	40045C	Hex Nut 1-5/16"
8	40551C	Tailpipe
9	45392C	Bubbler
10	45464C	Drain Plug 1-1/2"
11	45826C	Fountain Body
12	45832C	Access Panel
13	45833C	Bottom Cover
14	45734C	Drain Tube
15	45662C	Push Button
16	45663C	Push Button Sleeve
17	50986C	Regulator Holder
18	56121C	Drain Elbow 1-1/4"
19	55913C	Drain Adaptor
20	56092C	Poly Tubing (Cut To Length)
21	55996C	In - Line Strainer
22	61313C	Regulator
23	66346C	Drain Tube
24	70022C	Set Screw #6-32 x .31"
25	70852C	Tee - 3/8"
26	28208C	Basin
27	75535C	Pinned Torx Screw 1/4-20 x .75"
28	75564C	Lockwasher
29	75588C	Slip Joint Nut 1-1/4"
30	75589C	Gasket
NS	75521C	Torx Bit (T-27)
NS	75539C	Allen Wrench (1/16)
NS	75596C	Paint Touch-up (Pen)

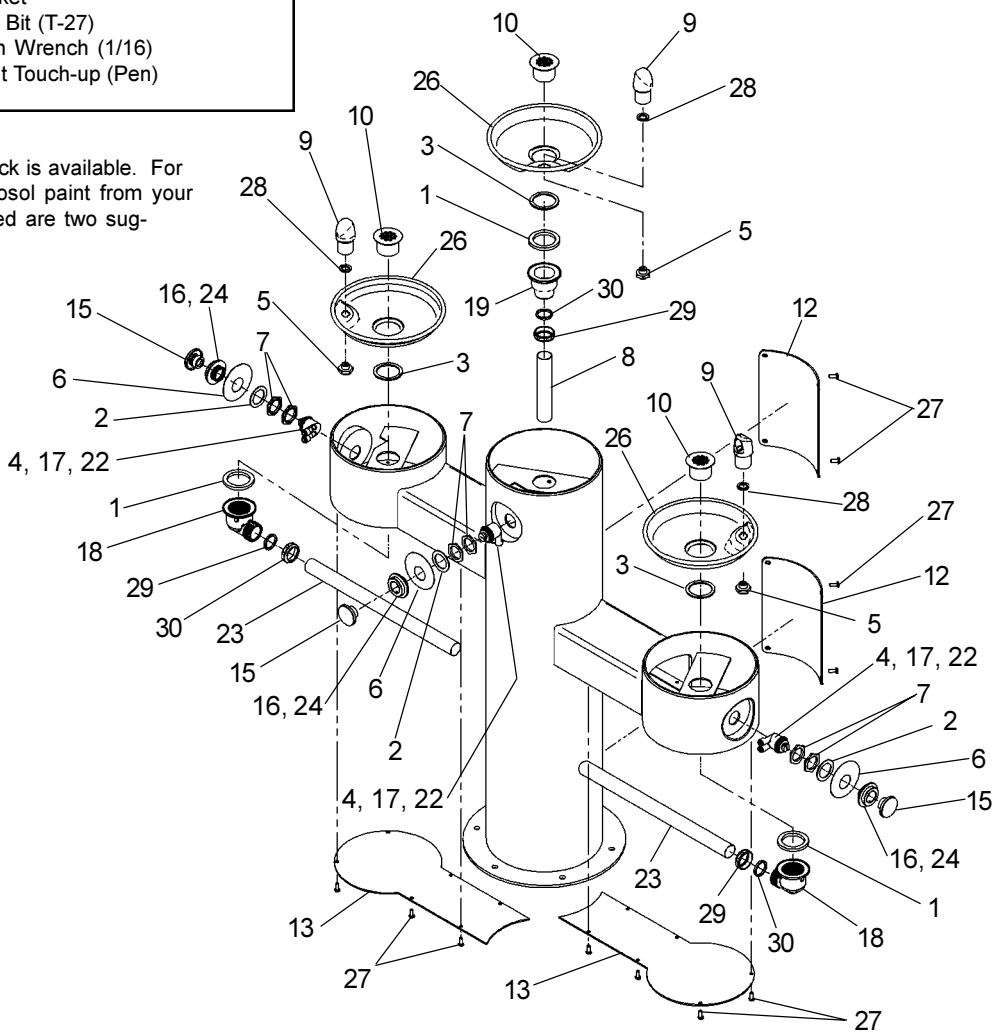
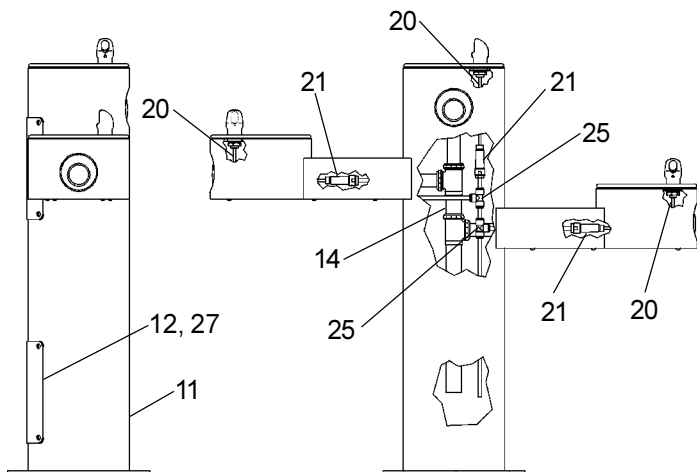

Touch-up Paint

For minor scratches a Touch-up Paint Stick is available. For repairing large defects, off-the-shelf aerosol paint from your local hardware store can be used. Listed are two suggested brandnames.

- Brandname: X-O
XO-11 Hunter Green
- Brandname: Ace Hardware
Rust Stop / Machine & Implement
International Green

Halsey Taylor
 2222 CAMDEN COURT
 OAK BROOK, IL 60523
 630.574.3500
 PRINTED IN U.S.A.

FOR PARTS, CONTACT YOUR LOCAL DISTRIBUTOR OR CALL 1.800.323.0620