

SERVICE INSTRUCTIONS

...with Illustrated Parts Breakdown

EBCO®

DEHUMIDIFIER MODELS:
AQUA-DRI
15A 25A 30A
25A-1

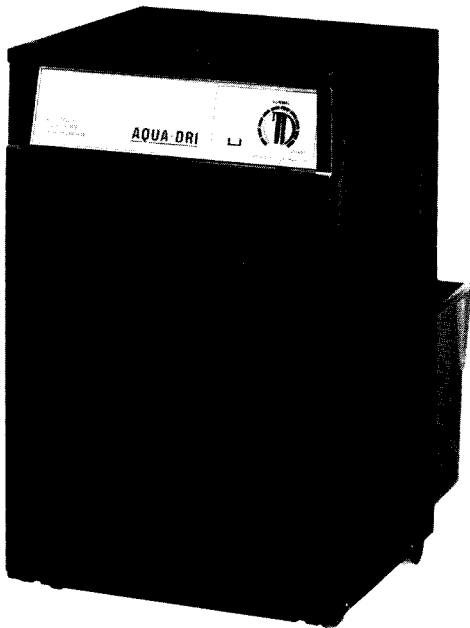

DESCRIPTION

Dehumidifiers are used to prevent moisture damage in basements, laundry rooms and any other enclosed areas in your home. These units plug into standard wall outlets and have a sealed refrigeration system with a quiet running fan.

SPECIFICATIONS

Voltage	115 VAC ±10%/1PH/60 Hertz
Size	21" H., 13" W., 17" D.
Shipping Weight (Approx)	47 LBS.

Models:	15A	25A	25A-1 30A
Capacity, Pint	15	25	30
Compressor, HP	1/6	1/5	1/4
Amps	3.3	5.0	5.5
Ref. Charge, OZ./R-12	5-3/4	11-1/2	9-5/8
Oil Charge, OZ.	10	10	10

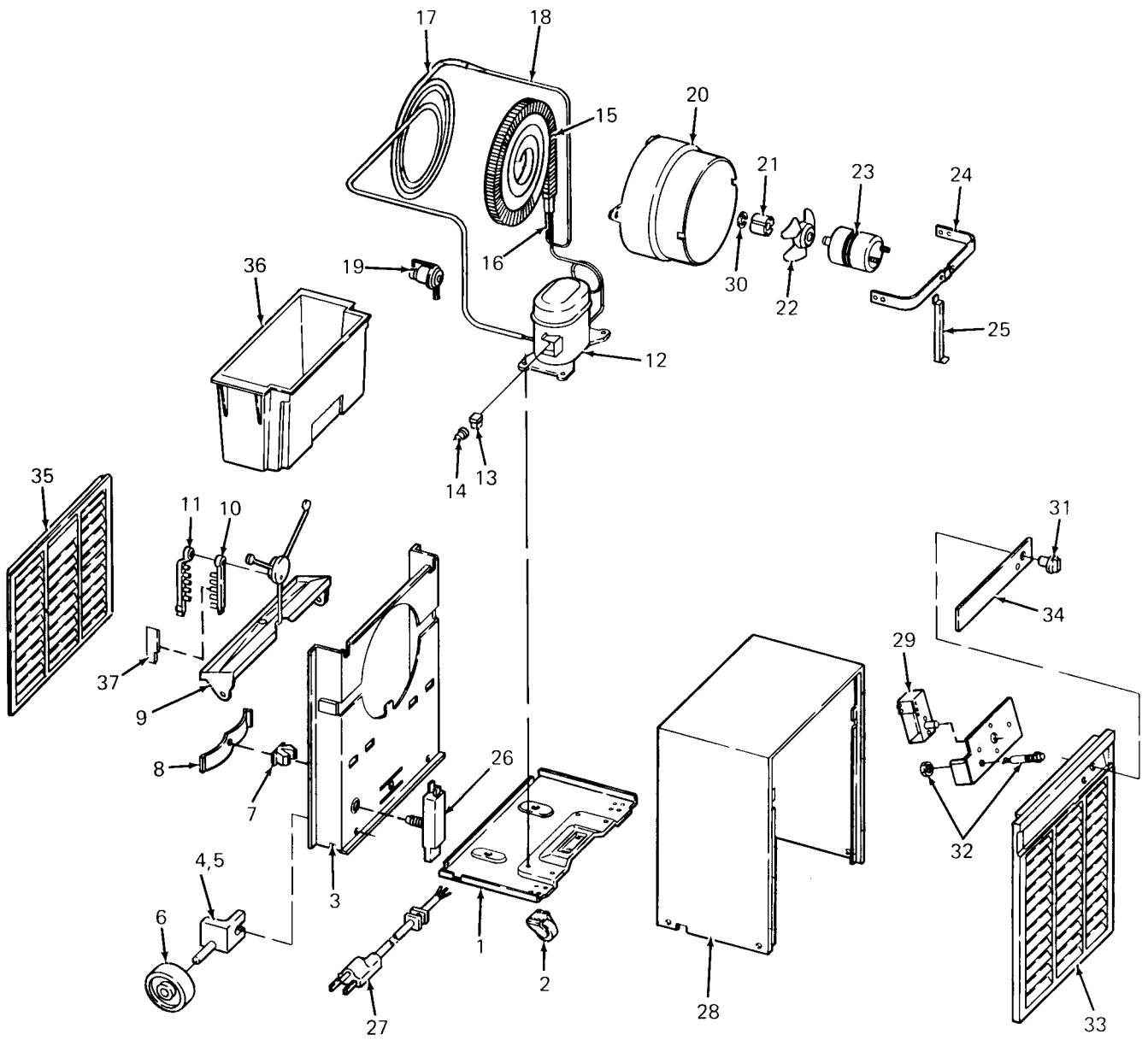

PARTS LIST

ITEM NO.	DESCRIPTION	15A	25A	25A-1 30A
1	Base	400651	400651	400651
2	Caster	400625	400625	400625
3	Support Column	400652	400652	400652
4	Left Wheel Support	400630	400630	400630
5	Right Wheel Support	400629	400629	400629
6	Wheel	400624	400624	400624
7	Spring Mounting Grommet	400653	400653	400653
8	Bucket Spring	400626	400626	400626
9	Evaporator Drain	400628	400628	400628
10	Evaporator Grommet A	400654	400654	400654
11	Evaporator Grommet B	400655	400655	400655
12	Compressor (See Below)			
13	Relay (Samsung)	400608	400609	400609
14	Overload (Samsung)	400604	400605	400606
15	Condenser	400618	400616	400617
16	Strainer	400615	400615	400615
17	Evaporator	400620	400619	400619
18	Capillary Tube	400613	400612	400614
19	Defrost Control	400669	400669	400669
20	Fan Shroud	400639	400639	400639
21	Ring Clip	400662	400662	400662
22	Fan Blade	400623	400623	400623
23	Fan Motor	400603	400603	400603
24	Fan Motor Bracket	400663	400663	400663
25	Bracket Support	400664	400664	400664
26	Overflow Shut Off Switch	400602	400602	400602
27	Service Cord	400665	400665	400665
28	Cabinet	400666	400666	400666
29	Humidistat	400611	400611	400611
30	E Ring	400667	400667	400667
31	Humidistat Knob	400633	400633	400633
32	Pilot Light	400601	400601	400601
33	Front Grille	400631	400631	400631
34	Grille Inlay	400636	400635	400637
35	Rear Grille	400632	400632	400632
36	Bucket	400627	400627	400627
37	Evaporator Grommet C	400650	---	---
---	Evaporator Bracket	---	400648	400648
---	Pilot Light Lens	400634	400634	400634

Replacement Compressor

Tecumseh Compressor (Includes Relay and Overload)

Compressor	017287	027256-002	027495-007
Relay	017289	017978	018461
Overload	017290	017977	022456
Refrigerant Charge	5-3/4 OZ	11-1/2 OZ	9-5/8 OZ
Refrigerant	R-12	R-12	R-12

---No illustration of part on form

ELECTRICAL DIAGRAM

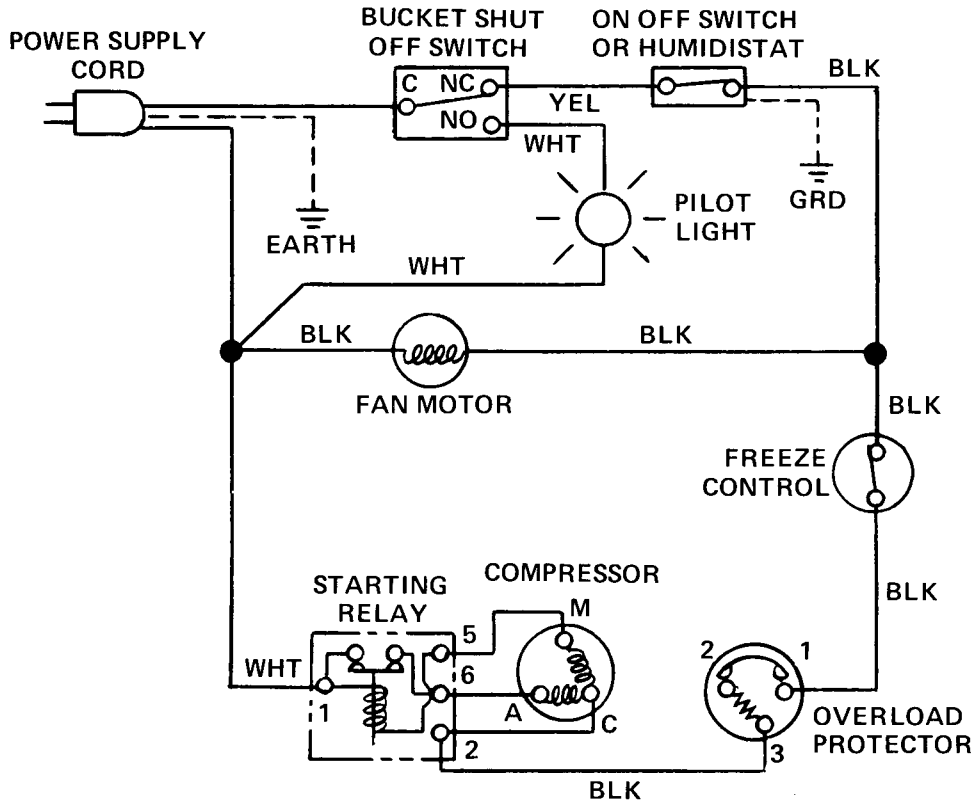

EBCO[®] MANUFACTURING COMPANY

265 N. Hamilton Rd. • P.O. Box 13150 • Columbus, OH 43213-0150 • 614/861-1350 • Fax: 614/861-5017